

R (RF, RX, RXF) ...Y...

电机用户自配或配特殊电机时
需加联接法兰

When equipping the user's motor or the special one, the flange is required to be connected

R系列减速机有以下设计方案：

R series gear units are available in the following designs:

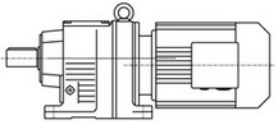

R...Y...

底脚轴伸式安装斜齿轮减速机
Foot-mounted helical gear units with solid shaft

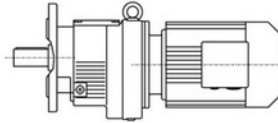

RF...Y...

法兰轴伸式安装斜齿轮减速机
Flange-mounted helical gear units with solid shaft

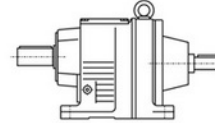

RS...

底脚轴伸式安装，轴输入的斜齿轮减速机
Foot-mounted, shaft input helical gear units with solid shaft

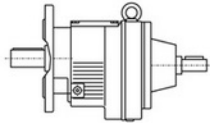

RFS...

法兰轴伸式，轴输入的斜齿轮减速机
Flange-mounted, shaft input helical gear units with solid shaft

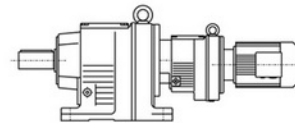

R...R...Y...

底脚轴伸式安装组合型斜齿轮减速机
Foot-mounted combinatorial helical gear units with solid shaft

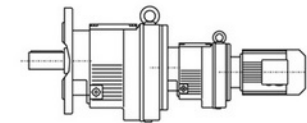

RF...R...Y...

法兰轴伸式组合型斜齿轮减速机
Flange-mounted combinatorial helical gear units with solid shaft

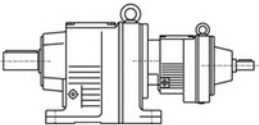

RS...R...

底脚轴伸式安装组合型，轴输入的斜齿轮减速机
Foot-mounted combinatorial, shaft input helical gear units with solid shaft

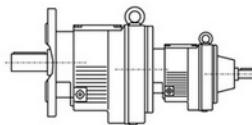

RFS...R...

法兰轴伸式组合型，轴输入的斜齿轮减速机
Flange-mounted combinatorial, shaft input helical gear units with solid shaft

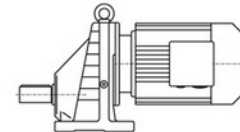

RX...Y...

底脚轴伸式安装单级斜齿轮减速机
Foot-mounted single-stage helical gear units with solid shaft

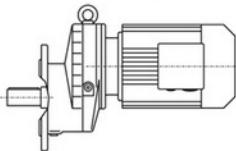

RXF...Y...

法兰轴伸式安装单级斜齿轮减速机
Flange-mounted single-stage helical gear units with solid shaft

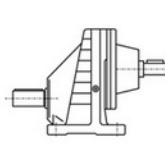

RXS...

底脚轴伸式安装，轴输入的单级斜齿轮减速机
Foot-mounted, shaft input single-stage helical gear units with solid shaft

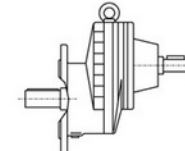

RXFS...

法兰轴伸式，轴输入的单级斜齿轮减速机
Flange-mounted, shaft input single-stage helical gear units with solid shaft

型号与标记:

Type Designations:

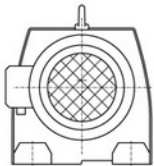
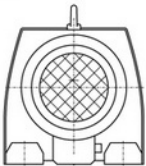
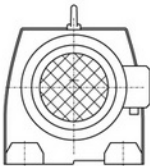
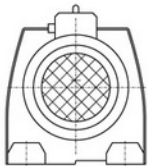
<p>R F 37-Y 0.55-4P-32.40-M1-270°-Φ200</p> <p>减速机类型 结构形式 规格 电机代号 电机功率、极数 传动比 安装形式 电机接线盒位置 输出法兰外径</p>	<p>R F 37-Y 0.55-4P-32.40-M1-270°-Φ200</p> <p>Gear units type Structure Size Motor code Motor power, pole Ratio Mounting position Position of the motor thermal box Outer diameter of output flange</p>
<p>减速机类型: 斜齿轮硬齿面减速机</p>	<p>Gear units type: rigid tooth flank helical gear units</p>
<p>结构形式: 普通轴伸式 (省略) 轴伸法兰式 F 普通轴伸式, 轴输入 S 轴伸法兰式, 轴输入 FS</p>	<p>Structure: Foot-mounted solid shaft output (-) Flange-mounted solid shaft output F Foot-mounted solid shaft output, shaft input S Flange-mounted solid shaft output, shaft input FS</p>
<p>规格: (见选型参数表)</p>	<p>Size: (see selection table)</p>
<p>电机代号: 普通 (更新) Y(Y2) 防爆 B 直流 Z 制动 YEJ 多速 D 变频 YVP 电磁调速 YCT 冶金起重 R 变频制动 YVPJ 辊道 G</p>	<p>Motor code: Ordinary(renew) Y(Y2) Flame-proof B Direct current Z Brake YEJ Multi-speed D Variable frequency YVP Electromagnetism speed modulation YCT Hoisting in metallurgy R Variable frequency and brake YVPJ Roller tables G</p>
<p>电机功率、极数: (见选型参数表)</p>	<p>Motor power, pole : (see selection table)</p>
<p>传动比: (见选型参数表)</p>	<p>Ratio: (see selection table)</p>
<p>安装形式: M1、M2、M3、M4、M5、M6 (见第9页)</p>	<p>Mounting position: M1、M2、M3、M4、M5、M6(see page 9)</p>
<p>电机接线盒位置: 0°、90°、180°、270° (见第8页)</p>	<p>Position of the motor thermal box: 0°、90°、180°、270° (see page 8)</p>
<p>输出法兰外径: (见外型安装尺寸图)底脚安装时省略</p>	<p>Outer diameter of output flange: (See the chart of mouting dimension sheets-overview) It will be omitted when foot mouting.</p>
<p>电机接线盒位置: Position of the motor thermal box:</p> <div style="display: flex; justify-content: space-around; align-items: center;">     </div> <p style="display: flex; justify-content: space-around; margin-top: 10px;"> 0° 90° 180° 270° </p>	

安装形式:

Mounting position:

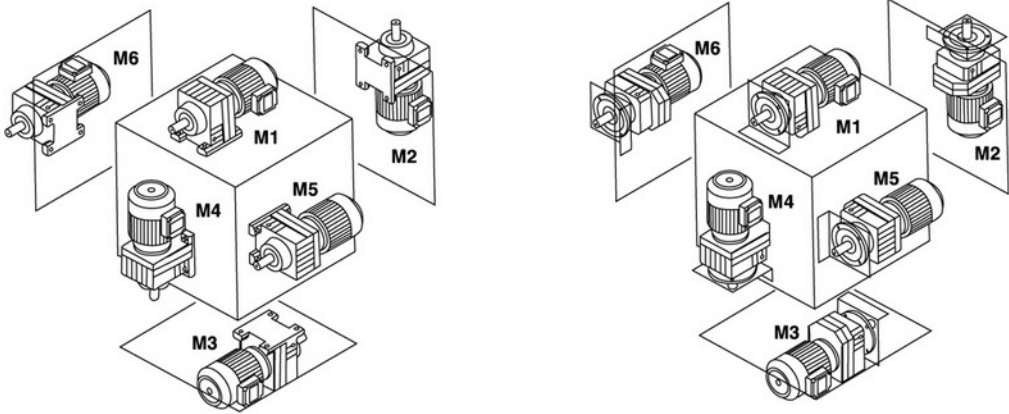

输入功率及许用转矩

Input power rating and permissible torque

规格 Size	17	27	37	47	57	67	77	87	97	107	137	147	167
结构形式 Structure	R						RF						
输入功率 Input power rating (kW)	0.18~0.75	0.18~3	0.18~3	0.18~5.5	0.18~7.5	0.18~7.5	0.18~11	0.55~22	0.55~30	2.2~45	5.5~55	11~90	11~160
传动比 Ratio	3.83~74.84	3.37~135.09	3.33~134.82	3.83~176.88	4.39~186.89	4.29~199.81	5.21~195.24	5.36~246.54	4.49~289.74	5.06~249.16	5.15~222.60	5.00~163.31	10.24~229.71
许用转矩 Permissible torque (N.m)	85	130	200	300	450	600	820	1550	3000	4300	8000	13000	18000

规格 Size	37	57	67	77	87	97	107	127	157
结构形式 Structure	RX				RXF				
输入功率 (kW) Input power rating	0.18~1.1	0.18~5.5	0.18~7.5	1.1~11	3~22	5.5~30	7.5~45	7.5~90	11~132
传动比 Ratio	1.62~4.43	1.3~5.5	1.4~6.07	1.42~8.00	1.39~8.65	1.42~8.23	1.44~6.63	1.51~6.2	1.57~6.2
许用转矩 (N.m) Permissible torque	20	70	135	215	400	600	830	1110	1680

减速机重量

Gear unit weight

规格 Size	R17	R27	R37	R47	R57	R67	R77	R87	R97	R107	R137	R147	R167
重量 (kg) Weight	4	5.5	8.5	10	18	25	36	63	101	153	220	400	700
机型号 Gear unit type	RX37	RX57	RX67	RX77	RX87	RX97	RX107	RX127	RX157				
重量 (kg) Weight	5	8	14	23	39	70	100	150	250				

所注重量为平均值, 仅供参考

The weights are mean values, only for reference.

润滑油量表
Lubrication table

规格 Size	润滑油量 (升) Fill quantity in liters					
	M1 ¹⁾	M2 ¹⁾	M3	M4	M5	M6
R17	0.25	0.6	0.35	0.6	0.35	0.35
R27	0.25/0.4	0.7	0.4	0.7	0.4	0.4
R37	0.3/1	0.9	1	1.1	0.8	1
R47	0.7/1.5	1.6	1.5	1.7	1.5	1.5
R57	0.8/1.7	1.9	1.7	2.1	1.7	1.7
R67	1.1/2.3	2.6/3.5	2.8	3.2	1.8	2
R77	1.2/3	3.8/4.3	3.6	4.3	2.5	3.4
R87	2.3/6	6.7/8.4	7.2	7.7	6.3	6.5
R97	4.6/9.8	11.7/14	11.7	13.4	11.3	11.7
R107	6/13.7	16.3	16.9	19.2	13.2	15.9
R137	10/25	28	29.5	31.5	25	25
R147	15.4/40	46.5	48	52	39.5	41
R167	27/70	82	78	88	66	69

规格 Size	润滑油量 (升) Fill quantity in liters					
	M1 ¹⁾	M2 ¹⁾	M3	M4	M5	M6
RF17	0.25	0.6	0.35	0.6	0.35	0.35
RF27	0.25/0.4	0.7	0.4	0.7	0.4	0.4
RF37	0.4/1	0.9	1	1.1	0.8	1
RF47	0.75/1.5	1.6	1.5	1.7	1.5	1.5
RF57	0.8/1.7	1.8	1.7	2	1.7	1.7
RF67	1.2/2.5	2.7/3.6	2.7	3.1	1.9	2.1
RF77	1.2/2.6	3.8/4.1	3.3	4.1	2.4	3
RF87	2.4/6	6.8/7.9	7.1	7.7	6.3	6.4
RF97	5.1/10.2	11.9/14	11.2	14	11.2	11.8
RF107	6.3/14.9	15.9	17	19.2	13.1	15.9
RF137	9.5/25	27	29	32.5	25	25
RF147	16.4/42	47	48	52	42	42
RF167	26/70	82	78	88	65	71

规格 Size	润滑油量 (升) Fill quantity in liters					
	M1	M2	M3	M4	M5	M6
RX37/RXF37	0.45/0.4	0.6	1.1/0.9	1.1/0.9	0.7/0.6	0.7/0.6
RX57/RXF57	0.6/0.5	0.8	1.3/1.1	1.3/1.1	0.9/0.7	0.9/0.7
RX67/RXF67	0.8/0.7	0.8	1.7/1.5	1.9/1.7	1.1/1	1.1/1
RX77/RXF77	1.1/0.9	1.5	2.6/2.4	2.7/2.5	1.6	1.6
RX87/RXF87	1.7/1.6	2.5	4.8/4.9	4.8/4.7	2.9	2.9
RX97/RXF97	2.1	3.4/3.6	7.4/7.1	7	4.8	4.8
RX107/RXF107	3.9/3.1	5.6/5.9	11.6/11.2	11.9/10.5	7.7/7.2	7.7/7.2
RX127/RXF127	5.6/5.9	11.6/11.2	21.9/20.5	22.7/22.2	9.7/9.2	9.7/9.2
RX157/RXF157	11.6/11.2	21.9/20.5	31.3/30.5	32.7/32.2	13.2/12.7	13.2/12.7

注：1) 表示减速机为组合型时低速级所加油量为大值。

Notes: 1) The large gear unit of multi-stage gear units must be filled with the larger oil volume.

输出转速	输出扭矩	传动比	使用系数	机型号	极数	输出转速	输出扭矩	传动比	使用系数	机型号	极数				
Output speed	Output torque	Ratio	Service factor	Type	Pole	Output speed	Output torque	Ratio	Service factor	Type	Pole				
r/min	Nm	i	f _s	Type	p	r/min	Nm	i	f _s	Type	p				
0.18kW						0.18kW									
0.16	9293	8443	1.31	R 147R77 RF147R77	4	1.6	944	858	0.82	R 77R37 RF77R37	4				
0.19	8042	7307	1.52			1.7	904	821	0.85						
0.22	7096	6447	1.72			1.8	833	757	0.93						
0.25	6128	5568	1.99			1.9	803	730	0.96						
0.29	5300	4815	2.31			2.1	739	671	1.04						
0.32	4760	4325	2.57			2.2	711	646	1.08						
0.38	4038	3669	3.03			2.4	628	571	1.23						
0.43	3553	3228	3.44			2.5	602	547	1.28						
0.16	9668	8784	0.8	R 137R77 RF137R77	4	2.9	525	477	1.47	R 67R37 RF67R37	4				
0.19	8232	7479	0.91			3.3	469	426	1.64						
0.22	7057	6412	1.07			3.8	402	365	1.92						
0.24	6421	5834	1.17			4.5	341	310	2.26						
0.28	5504	5001	1.37			2.4	628	571	0.90						
0.30	5183	4709	1.45			2.5	617	561	0.91						
0.32	4803	4364	1.57			2.9	532	483	1.06						
0.35	4323	3928	1.74			3.2	482	438	1.17						
0.40	3868	3514	1.94			3.6	427	388	1.32						
0.42	3674	3338	2.05			4.1	370	336	1.53						
0.47	3224	2929	2.33	4.8	316	287	1.79								
						5.5	281	255	2.01						
0.31	4881	4435	0.83	R 107R77 RF107R77	4	3.0	518	471	0.82	R 57R37 RF57R37	4				
0.36	4260	3870	0.95			3.1	488	443	0.87						
0.42	3634	3302	1.11			3.4	451	410	0.94						
0.46	3299	2997	1.23			3.9	395	359	1.07						
0.53	2885	2621	1.40			4.3	357	324	1.19						
0.62	2479	2252	1.63			4.4	351	319	1.20						
0.68	2246	2041	1.80			4.8	319	290	1.33						
0.71	2169	1971	1.86			5.2	294	267	1.44						
0.77	1995	1813	2.03			5.3	288	262	1.47						
0.88	1747	1587	2.31			5.7	271	246	1.56						
1.0	1529	1389	2.64			5.8	265	241	1.59						
1.1	1338	1216	3.02			6.3	242	220	1.75						
								6.5	237			215	1.79		
								7.4	207			188	2.04		
						8.7	175	159	2.42						
0.51	2996	2722	0.94	R 97R57 RF97R57	4	4.6	331	301	0.85	R 47R37 RF47R37	4				
0.52	2937	2668	0.96			5.5	281	255	1.00						
0.60	2544	2311	1.11			6.1	251	228	1.12						
0.62	2471	2245	1.14			7.1	215	195	1.31						
0.67	2287	2078	1.23			6.2	249	226	0.8						
0.69	2219	2016	1.27			6.9	222	202	0.85						
0.80	1907	1733	1.48			7.0	219	199	0.86						
0.86	1786	1623	1.58			7.8	197	179	0.95						
0.97	1578	1434	1.79			8.9	173	157	1.09						
1.2	1328	1207	2.12			9.1	172	156	1.11						
1.3	1193	1084	2.36	9.3	165	150	1.14								
1.5	1028	934	2.74												
1.6	966	878	2.92												
1.8	831	755	3.39												
0.79	1912	1737	0.8	R 87R57 RF87R57	4	9.9	155	141	0.8	R 27R17 RF27R17	4				
0.80	1907	1733	0.85			10	149	135	0.82						
0.91	1677	1524	0.87			11	136	124	0.90						
0.93	1639	1489	0.89			12	130	118	0.94						
1.0	1535	1395	0.95			13	121	110	1.01						
1.1	1356	1232	1.07			14	114	104	1.07						
1.2	1260	1145	1.16			15	103	94	1.18						
1.3	1141	1037	1.28												
1.5	1025	931	1.42			4.4	371	195.24	2.1			R 77 RF77	6		
1.6	972	883	1.50			5.1	317	166.59	2.4						
1.7	883	802	1.65	5.8	277	145.67	2.8								
1.8	852	774	1.71	6.1	263	138.39	2.9								
				7.0	231	121.42	3.3								

R

输出转速	输出扭矩	传动比	使用系数	机型号	极数	输出转速	输出扭矩	传动比	使用系数	机型号	极数
Output speed	Output torque	Ratio	Service factor	Type	Pole	Output speed	Output torque	Ratio	Service factor	Type	Pole
r/min	Nm	i	f _s	Type	p	r/min	Nm	i	f _s	Type	p
0.18kW						0.18kW					
7.1	227	195.24	3.4			11	144	123.91	0.85		
8.3	194	166.59	4.0	R 77	4	13	123	105.49	1.00		
9.5	169	145.67	4.6	RF77	4	15	106	90.96	1.16		
10	161	138.39	4.8			16	99	84.78	1.24		
						19	86	74.11	1.42		
4.3	380	199.81	1.48			20	81	69.47	1.51		
4.6	350	184.07	1.61			23	71	61.30	1.71		
5.4	301	158.14	1.88			25	65	55.87	1.88		
6.2	262	137.67	2.2			29	56	48.17	2.2		
6.6	245	128.97	2.3	R 67	6	31	52	44.90	2.3	R 27	4
7.5	217	113.94	2.6	RF67	6	35	46	39.25	2.7	RF27	4
8.0	201	105.83	2.8			38	44	36.79	2.8		
8.9	182	95.91	3.1			43	39	32.47	3.2		
9.9	164	86.11	3.4			48	35	28.78	3.5		
11	141	74.17	4.0			49	34	28.37	3.6		
12	133	69.75	4.3			53	31	26.09	3.9		
						57	29	24.47	4.2		
7.0	232	199.81	2.4			62	26	22.32	4.6		
7.6	214	184.07	2.6			72	23	19.35	5.3		
8.8	184	158.14	3.1	R 67	4	77	21	18.08	5.7		
10	160	137.67	3.5	RF67	4	89	19	15.63	6.6		
11	150	128.97	3.8			105	16	13.28	7.8		
12	132	113.94	4.3								
13	123	105.83	4.6			37	45	23.13	1.78	R 17	6
						40	41	21.22	1.94	RF17	6
						47	35	18.06	2.28		
4.5	355	186.89	1.19			19	87	74.84	0.92		
4.9	327	172.17	1.29	R 57	6	22	75	64.52	1.07		
5.7	281	147.92	1.50	RF57	6	23	70	60.14	1.14		
6.6	245	128.77	1.73			26	61	52.57	1.31		
7.0	229	120.63	1.84			28	57	49.28	1.39		
						32	51	43.49	1.58		
7.4	217	186.89	1.95			34	47	40.49	1.70		
8.1	200	172.17	2.1			39	41	35.40	1.94		
9.4	172	147.92	2.5	R 57	4	42	39	33.18	2.07		
11	150	128.77	2.8	RF57	4	47	34	29.28	2.3		
12	140	120.63	3.0			54	30	25.96	2.6		
13	124	106.58	3.4			60	27	23.13	2.9		
14	115	98.99	3.7			63	26	22.06	3.1		
15	104	89.71	4.1			66	25	21.22	3.2		
						77	21	18.06	3.7		
7.9	206	176.88	1.37			89	18	15.57	4.3	R 17	4
8.5	189	162.94	1.49			96	17	14.52	4.6	RF17	4
9.9	163	139.99	1.73			110	15	12.69	5.3		
11	142	121.87	1.99	R 47	4	117	14	11.89	5.7		
12	133	114.17	2.1	RF47	4	132	12	10.5	5.9		
14	117	100.86	2.4			149	11	9.31	6.1		
15	109	93.68	2.6			176	10	7.91	6.2		
16	99	84.90	2.9			184	9	7.55	6.5		
18	89	76.23	3.2			197	8	7.04	7.0		
						226	7.5	6.15	7.2		
6.9	235	123.66	0.80			241	7	5.76	7.3		
8.1	200	105.28	0.94	R 37	6	273	6	5.09	7.9		
9.4	173	90.77	1.09	RF37	6	308	5	4.51	8.4		
10	161	84.61	1.17			363	4.5	3.83	10		
10	157	134.82	1.20			140	12	6.07	3.4		
11	144	123.66	1.31			164	10	5.18	6.9	RX 67	6
13	122	105.28	1.54			188	9.0	4.53	8.6	RXF67	6
15	106	90.77	1.78			198	8.5	4.30	8.8		
16	98	84.61	1.91	R 37	4						
19	86	73.96	2.2	RF37	4						
20	81	69.33	2.3								
23	71	61.18	2.6								
25	65	55.76	2.9								
29	56	48.08	3.1								

R

输出转速 Output speed r/min	输出扭矩 Output torque Nm	传动比 Ratio i	使用系数 Service factor f _s	机型号 Type Type	极数 Pole p	输出转速 Output speed r/min	输出扭矩 Output torque Nm	传动比 Ratio i	使用系数 Service factor f _s	机型号 Type Type	极数 Pole p
0.18kW						0.25kW					
229	7.4	6.07	5.5			0.69	3082	2016	0.92		
268	6.3	5.18	11			0.76	2787	1823	1.01		
307	5.5	4.53	13			0.80	2649	1733	1.06		
323	5.2	4.30	14			0.86	2481	1623	1.14		
369	4.6	3.77	18	RX 67	4	0.88	2420	1583	1.17	R 97R57	4
434	3.9	3.20	24	RXF67	4	1.0	2134	1396	1.32	RF97R57	4
481	3.5	2.89	28			1.1	1877	1228	1.50		
547	3.1	2.54	36			1.3	1633	1068	1.73		
579	2.9	2.40	40			1.5	1432	937	1.97		
681	2.5	2.04	51			1.7	1260	824	2.2		
						1.9	1127	737	2.5		
						2.2	965	631	2.9		
155	11	5.50	3.36			1.2	1750	1145	0.83		
168	10	5.07	3.37	RX 57	6	1.3	1585	1037	0.92		
195	8.6	4.35	7.4	RXF57	6	1.5	1423	931	1.02		
224	7.5	3.79	8.5			1.6	1350	883	1.08		
253	6.7	5.50	5.50			1.7	1226	802	1.19		
274	6.1	5.07	5.51			1.8	1183	774	1.23	R 87R57	4
320	5.3	4.35	12			2.0	1044	683	1.40	RF87R57	4
367	4.6	3.79	14			2.3	916	599	1.59		
392	4.3	3.55	15			2.6	803	525	1.82		
443	3.8	3.14	16	RX 57	4	3.1	694	454	2.1		
478	3.5	2.91	18	RXF57	4	5.2	408	267	3.6		
527	3.2	2.64	20			2.4	873	571	0.88		
586	2.9	2.37	23			2.5	836	547	0.92		
681	2.5	2.04	26			2.9	729	477	1.06		
724	2.3	1.92	28			3.3	651	426	1.18	R 77R37	4
842	2.0	1.65	32			3.8	556	364	1.39	RF77R37	4
426	4	3.26	3.80	RX 37	4	4.5	477	312	1.62		
527	3	2.64	4.69	RXF37	4	4.6	474	310	1.63		
0.25kW						0.25kW					
0.14	14894	9743	0.82			5.6	379	248	2.03		
0.16	12907	8443	0.95			6.3	335	219	2.3		
0.19	11170	7307	1.09			3.6	593	388	0.95		
0.22	9855	6447	1.24	R 147R77	4	3.9	549	359	1.03		
0.25	8512	5568	1.44	RF147R77	4	4.1	514	336	1.10		
0.29	7361	4815	1.66			4.5	474	310	1.19		
0.32	6612	4325	1.85			4.8	439	287	1.29		
0.38	5609	3669	2.18			5.3	404	264	1.40		
0.43	4935	3228	2.48			5.5	390	255	1.45	R 67R37	4
0.49	4331	2833	2.82			5.9	359	235	1.57	RF67R37	4
0.24	8918	5834	0.84			6.1	350	229	1.61		
0.28	7645	5001	0.98			6.9	307	201	1.84		
0.30	7199	4709	1.04			7.1	298	195	1.89		
0.32	6671	4364	1.13			7.7	277	181	2.0		
0.35	6142	4018	1.22			8.1	263	172	2.15		
0.37	6005	3928	1.25	R 137R77	4	9.0	235	154	2.40		
0.40	5372	3514	1.40	RF137R77	4	4.3	495	324	0.85		
0.42	5103	3338	1.47			4.4	488	319	0.87		
0.47	4478	2929	1.68			4.8	443	290	0.95		
0.52	4063	2658	1.85			5.2	408	267	1.04		
0.58	3687	2414	2.0			5.3	401	262	1.06		
0.67	3169	2073	2.4			5.7	376	246	1.12	R 57R37	4
0.76	2811	1839	2.7			5.8	368	241	1.15	RF57R37	4
0.99	2136	1397	3.5			6.3	336	220	1.26		
1.1	1874	1226	4.0			6.5	329	215	1.29		
0.46	4609	3015	0.88			7.6	280	183	1.51		
0.71	3013	1971	1.34			8.6	246	161	1.72		
0.77	2772	1813	1.46			10	211	138	2.0		
0.88	2426	1587	1.67			6.1	349	228	0.81		
1.0	2123	1389	1.90	R 107R77	4	7.1	298	195	0.95	R 47R37	4
1.1	1859	1216	2.2	RF107R77	4	7.6	278	182	1.01	RF47R37	4
1.5	1417	927	2.9			9.0	235	154	1.20		
1.7	1241	812	3.3								

R

输出转速 Output speed r/min	输出扭矩 Output torque Nm	传动比 Ratio i	使用系数 Service factor f _s	机型号 Type Type	极数 Pole p	输出转速 Output speed r/min	输出扭矩 Output torque Nm	传动比 Ratio i	使用系数 Service factor f _s	机型号 Type Type	极数 Pole p
0.25kW						0.25kW					
8.9	238	156	0.79	R 37R17 RF37R17	4	7.4	308	186.89	1.37	R 57 RF57	4
9.3	229	150	0.82			8.1	284	172.17	1.49		
10	206	135	0.91			9.4	244	147.92	1.73		
11	194	127	0.97			11	212	128.77	1.99		
12	168	110	1.12			12	199	120.63	2.1		
13	159	104	1.18			13	176	106.58	2.4		
14	144	94	1.31			14	163	98.99	2.6		
15	138	90	1.37			15	148	89.71	2.9		
2.2	1029	289.60	2.7	R 97	8	17	133	80.55	3.2	R 47 RF47	4
2.5	913	256.89	3.1	RF97	8	20	114	69.23	3.7		
2.7	856	240.83	3.3	R 87 RF87	8	7.9	292	176.88	0.97		
3.0	767	215.94	3.7			8.5	269	162.94	1.05		
2.6	876	246.54	1.66			9.9	231	139.99	1.22		
3.0	769	216.54	1.89			11	201	121.87	1.40		
3.1	731	205.71	1.99			12	188	114.17	1.50		
3.5	646	181.77	2.3			14	166	100.86	1.70		
3.9	592	166.59	1.30			15	154	93.68	1.83		
4.4	518	145.67	1.49			16	140	84.90	2.0		
4.7	492	138.39	1.57	18	126	76.23	2.2	R 77 RF77	8	R 37 RF37	4
5.3	431	121.42	1.79	20	113	68.54	2.5				
4.4	526	195.24	1.46	22	106	64.21	2.7				
5.1	449	166.59	1.72	25	94	56.73	3.0				
5.8	393	145.67	1.96	26	87	52.69	3.2				
7.1	322	195.24	2.4	29	79	47.75	3.6				
8.3	275	166.59	2.8	10	222	134.82	0.85				
9.5	240	145.67	3.2	11	204	123.66	0.92				
10	228	138.39	3.4	13	175	105.28	1.08				
11	200	121.42	3.8	15	150	90.77	1.26				
4.1	562	158.14	1.00	16	140	84.61	1.35	R 67 RF67	8	R 27 RF27	4
4.7	489	137.67	1.15	19	122	73.96	1.54				
5.0	458	128.97	1.23	20	114	69.33	1.64				
5.7	405	113.94	1.39	23	101	61.18	1.86				
4.3	539	199.81	1.05	25	92	55.76	2.0				
4.6	496	184.07	1.14	29	79	48.08	2.4				
5.4	426	158.14	1.32	31	74	44.81	2.5				
6.2	371	137.67	1.52	35	65	39.17	2.9				
6.6	348	128.97	1.62	38	61	36.72	3.1				
7.5	307	113.94	1.84	43	53	32.40	3.5				
8.0	285	105.83	1.98	16	140	84.78	0.87	R 67 RF67	6	R 27 RF27	4
7.0	329	199.81	1.71	19	122	74.11	1.00				
7.6	304	184.07	1.86	20	115	69.47	1.07				
8.8	261	158.14	2.2	23	101	61.30	1.21				
10	227	137.67	2.5	25	92	55.87	1.33				
11	213	128.97	2.7	29	79	48.17	1.54				
12	188	113.94	3.0	31	74	44.90	1.65				
13	175	105.83	3.2	35	65	39.25	1.89				
14	158	95.91	3.6	38	61	36.79	2.0				
16	142	86.11	4.0	43	54	32.47	2.3				
4.5	504	186.89	0.84	48	48	28.78	2.5	R 57 RF57	6	R 27 RF27	4
4.9	464	172.17	0.91	49	47	28.37	2.6				
5.7	399	147.92	1.06	53	43	26.09	2.8				
6.6	347	128.77	1.22	57	40	24.47	3.0				
7.0	325	120.63	1.30	62	37	22.32	3.3				
8.0	287	106.58	1.47	72	32	19.35	3.8				
8.6	267	98.99	1.58	77	30	18.08	4.1				
				89	26	15.63	4.7				
				105	22	13.28	5.6				
				117	20	11.86	6.2				
				137	17	10.13	6.9				
				148	16	9.41	7.4				
				170	14	8.16	8.1				
				182	13	7.63	8.4				
				211	11	6.59	9.2				
				248	9.0	5.60	10				
				278	8.2	5.00	11				
				326	7.0	4.27	12				
				348	7.0	4.00	12				
				412	6.0	3.37	13				

R

输出转速	输出扭矩	传动比	使用系数	机型号	极数	输出转速	输出扭矩	传动比	使用系数	机型号	极数
Output speed	Output torque	Ratio	Service factor	Type	Pole	Output speed	Output torque	Ratio	Service factor	Type	Pole
r/min	Nm	i	f _s	Type	p	r/min	Nm	i	f _s	Type	p
0.25kW						0.37kW					
26	87	52.57	0.92			0.19	16532	7307	0.80		
28	81	49.28	0.98			0.22	14586	6447	0.84		
32	72	43.49	1.11			0.25	12597	5568	0.97		
34	67	40.49	1.20			0.29	10894	4815	1.12	R 147R77	4
39	58	35.40	1.37			0.32	9785	4325	1.25	RF147R77	4
42	55	33.18	1.46			0.38	8301	3669	1.47		
47	48	29.28	1.65			0.43	7303	3228	1.67		
54	43	25.96	1.87			0.49	6410	2833	1.91		
60	38	23.13	2.1								
63	36	22.06	2.2			0.32	9873	4364	0.76		
66	35	21.22	2.3			0.35	8887	3928	0.85		
77	30	18.06	2.7	R 17	4	0.40	7950	3514	0.95		
89	26	15.57	3.1	RF17	4	0.42	7552	3338	1.00		
96	24	14.52	3.3			0.47	6627	2929	1.13		
110	21	12.69	3.8			0.52	6014	2658	1.25		
117	20	11.89	4.1			0.56	5620	2484	1.34	R 137R77	4
132	17	10.5	4.2			0.58	5457	2412	1.38	RF137R77	4
149	15	9.31	4.4			0.62	5072	2242	1.48		
176	13	7.91	4.5			0.67	4690	2073	1.60		
184	12	7.55	4.7			0.76	4161	1839	1.81		
197	11	7.04	5.0			0.99	3161	1397	2.4		
226	10	6.15	5.2			1.1	2774	1226	2.7		
241	9	5.76	5.3			1.3	2466	1090	3.0		
273	8	5.09	5.7			1.5	2152	951	3.5		
308	7	4.51	6.1								
363	6	3.83	6.7			0.68	4618	2041	0.88		
						0.71	4459	1971	0.91		
140	16	6.07	2.5	RX 67	6	0.77	4102	1813	0.99		
164	14	5.18	4.9	RXF67	6	0.83	3785	1673	1.07		
188	13	4.53	6.2			0.88	3591	1587	1.13	R 107R77	4
198	12	4.30	6.4			0.91	3464	1531	1.17	RF107R77	4
						1.0	3145	1390	1.29		
229	10	6.07	4.0			1.1	2751	1216	1.47		
268	9	5.18	8.1			1.2	2701	1194	1.50		
307	8	4.53	10			1.3	2360	1043	1.71		
323	7	4.30	10			1.5	2097	927	1.93		
369	6	3.77	13	RX 67	4	1.7	1837	812	2.2		
434	5.5	3.20	17	RXF67	4						
481	5	2.89	20			0.97	3244	1434	0.87		
547	4.5	2.54	26			1.0	3158	1396	0.89		
579	4	2.40	29			1.1	2778	1228	1.02		
681	3	2.04	37			1.2	2731	1207	1.03		
						1.3	2453	1084	1.15		
155	15	5.50	2.4			1.4	2416	1068	1.17	R 97R57	4
168	14	5.07	2.4	RX 57	6	1.5	2120	937	1.33	RF97R57	4
195	12	4.35	5.3	RXF57	6	1.7	1864	824	1.51		
224	10	3.79	6.2			1.9	1667	737	1.69		
						2.2	1428	631	1.98		
253	9.3	5.50	4.0			3.2	973	430	2.9		
274	8.5	5.07	4.0			3.7	857	379	3.3		
320	7.3	4.35	9.0			4.1	760	336	3.7		
367	6.4	3.79	10								
392	6.0	3.55	11			1.7	1814	802	0.80		
443	5.3	3.14	12	RX 57	4	1.8	1751	774	0.83		
478	4.9	2.91	13	RXF57	4	1.9	1706	754	0.85		
527	4.4	2.64	15			2.0	1545	683	0.94		
586	4.0	2.37	16			2.1	1468	649	0.99		
681	3.4	2.04	19			2.3	1355	599	1.08	R 87R57	4
724	3.2	1.92	20			2.5	1217	538	1.20	RF87R57	4
842	2.8	1.65	23			2.6	1188	525	1.23		
						2.9	1068	472	1.36		
370	6	3.76	2.37			3.1	1027	454	1.42		
426	5.5	3.26	2.73			3.5	905	400	1.61		
456	5	3.05	2.92			3.9	817	361	1.78		
527	4.5	2.64	3.38	RX 37	4	5.2	604	267	2.4		
621	4	2.24	3.98	RXF37	4	5.9	532	235	2.7		
695	3.5	2.00	4.46								
813	3	1.71	5.21								
869	2.5	1.60	5.57								

R

输出转速 Output speed r/min	输出扭矩 Output torque Nm	传动比 Ratio i	使用系数 Service factor f _s	机型号 Type Type	极数 Pole p	输出转速 Output speed r/min	输出扭矩 Output torque Nm	传动比 Ratio i	使用系数 Service factor f _s	机型号 Type Type	极数 Pole p
0.37kW						0.37kW					
3.3	964	426	0.80	R 77R37 RF77R37	4	6.6	503	128.77	0.84	R 57 RF57	6
3.8	824	364	0.94			7.0	471	120.63	0.90		
4.3	740	327	1.04			8.0	416	106.58	1.02		
4.5	701	310	1.10			8.6	387	98.99	1.09		
5.6	561	248	1.37			7.4	447	186.89	0.95		
6.3	495	219	1.56			8.1	411	172.17	1.03		
7.4	425	188	1.81			9.4	353	147.92	1.20		
8.6	367	162	2.1			11	308	128.77	1.37		
9.8	321	142	2.4			12	288	120.63	1.47		
4.8	649	287	0.87	R 67R37 RF67R37	4	13	255	106.58	1.66	R 57 RF57	4
5.5	577	255	0.98			14	237	98.99	1.79		
6.1	518	229	1.09			15	214	89.71	1.97		
7.1	441	195	1.28			17	192	80.55	2.2		
2.5	1323	256.89	2.1			20	165	69.23	2.6		
2.7	1240	240.83	2.3	R 97 RF97	8	21	155	64.85	2.7		
3.0	1112	215.94	2.5			24	137	57.29	3.1		
3.5	958	185.97	2.9	26	127	53.22	3.3				
2.9	1132	289.60	2.5	29	115	48.23	3.7				
3.3	1004	256.89	2.8	R 97 RF97	6	9.9	335	139.99	0.84		
3.5	941	240.83	3.0			11	291	121.87	0.97		
3.9	844	215.94	3.3	12	273	114.17	1.03				
3.0	1115	216.54	1.31	14	241	100.86	1.17				
3.1	1059	205.71	1.38	R 87 RF87	8	15	224	93.68	1.26		
3.5	936	181.77	1.6			16	203	84.90	1.39		
3.4	963	246.54	1.51	R 87 RF87	6	18	182	76.23	1.55		
3.9	846	216.54	1.72			20	164	68.54	1.72		
4.1	804	205.71	1.81			22	153	64.21	1.84		
4.7	710	181.77	2.1			25	136	56.73	2.1		
5.5	607	155.34	2.4			26	126	52.69	2.2		
6.0	556	142.41	2.6			29	114	47.75	2.5		
4.4	750	145.67	1.03			32	102	42.87	2.6		
4.7	713	138.39	1.08			38	88	36.93	2.7		
5.3	625	121.42	1.23	40	83	34.73	2.8				
5.1	651	166.59	1.18	R 77 RF77	8	41	81	33.79	3.2		
5.8	569	145.67	1.35			45	74	31.12	3.4		
6.1	541	138.39	1.43	52	64	26.74	4.4				
7.1	467	195.24	1.65	60	56	23.28	5.1				
8.3	398	166.59	1.94	64	52	21.81	5.4				
9.5	348	145.67	2.2	R 77 RF77	4	15	217	90.77	0.87		
10	331	138.39	2.3			16	202	84.61	0.93		
11	290	121.42	2.7			19	177	73.96	1.06		
13	246	102.99	3.1			20	166	69.33	1.13		
15	222	92.97	3.47			23	146	61.18	1.29		
5.4	618	158.14	0.91			25	133	55.76	1.41		
6.2	538	137.67	1.05			29	115	48.08	1.64		
6.6	504	128.97	1.12			31	107	44.81	1.76		
7.5	445	113.94	1.27	35	94	39.17	2.0				
7.0	477	199.81	1.18	R 67 RF67	6	38	88	36.72	2.1		
7.6	440	184.07	1.28			43	77	32.40	2.4		
8.8	378	158.14	1.49	48	69	28.73	2.7				
10	329	137.67	1.71	49	68	28.32	2.8				
11	308	128.97	1.83	53	62	26.03	2.9				
12	272	113.94	2.1	57	58	24.42	3.2				
13	253	105.83	2.2	62	53	22.27	3.5				
14	229	95.91	2.5	72	46	19.31	4.1				
16	206	86.11	2.7	77	43	18.05	4.4				
19	177	74.17	3.2	89	38	15.60	4.9				
20	167	69.75	3.4	105	32	13.25	5.5				
23	146	61.26	3.9	117	29	11.83	6.0				
24	136	56.89	4.1								

R

输出转速	输出扭矩	传动比	使用系数	机型号	极数	输出转速	输出扭矩	传动比	使用系数	机型号	极数
Output speed	Output torque	Ratio	Service factor	Type	Pole	Output speed	Output torque	Ratio	Service factor	Type	Pole
r/min	Nm	i	f _s	Type	p	r/min	Nm	i	f _s	Type	p
0.37kW						0.37kW					
23	146	61.30	0.83	R 27 RF27	4	253	13.7	5.50	2.7	RX 57 RXF57	4
25	134	55.87	0.92								
29	115	48.17	1.06								
31	107	44.90	1.14								
35	94	39.25	1.30								
38	88	36.79	1.39								
43	78	32.47	1.57								
48	69	28.78	1.78								
49	68	28.37	1.80								
53	62	26.09	1.96								
57	58	24.47	2.1								
62	53	22.32	2.3								
72	46	19.35	2.6								
77	43	18.08	2.8								
89	37	15.63	3.3								
105	32	13.28	3.9								
39	85	35.40	0.94	R 17 RF17	4	426	8.1	3.26	1.85	RX 37 RXF37	4
42	79	33.18	1.01								
47	70	29.28	1.14								
54	62	25.96	1.29								
60	55	23.13	1.45								
63	53	22.06	1.52								
66	51	21.22	1.58								
77	43	18.06	1.85								
89	37	15.57	2.1								
96	35	14.52	2.3								
110	30	12.69	2.6								
117	28	11.89	2.8								
132	25	10.50	2.9								
149	22	9.31	3.0								
176	19	7.91	3.1								
184	18	7.55	3.3								
197	17	7.04	3.4								
226	15	6.15	3.5								
241	14	5.76	3.6								
273	12	5.09	3.9								
308	11	4.51	4.2								
363	9	3.83	4.6								
164	21	5.18	3.3	RX 67 RXF67	6	0.55kW					
188	19	4.53	4.2								
198	18	4.30	4.3								
225	15	3.77	5.3								
229	15	6.07	2.7	RX 67 RXF67	4	0.23	20411	6069	0.83	R 167R97 RF167R97	4
268	13	5.18	5.5								
307	12	4.53	6.8								
323	11	4.30	7.0								
369	9	3.77	8.7								
434	8	3.20	12								
481	7	2.89	14								
547	6.3	2.54	18								
579	6.0	2.40	19								
681	5.1	2.04	25								
0.26	18157	5399	0.93			R 147R77 RF147R77	4				
0.30	15837	4709	1.07								
0.33	14065	4182	1.20								
0.29	16193	4815	0.75								
0.32	14545	4325	0.84								
0.38	12339	3669	0.99								
0.43	10856	3228	1.13								
0.49	9528	2833	1.28								
0.54	8593	2555	1.42								
0.63	7436	2211	1.64								
0.71	6561	1951	1.86								
0.82	5734	1705	2.1								
0.90	5166	1536	2.4								
1.05	4470	1329	2.7								
1.19	3921	1166	3.1								
0.52	8939	2658	0.84	R 137R77 RF137R77	4	1.0	4675	1390	0.86	R 107R77 RF107R77	4
0.56	8354	2484	0.9								
0.58	8112	2412	0.93								
0.67	6972	2073	1.08								
0.76	6185	1839	1.22								
0.87	5374	1598	1.40								
0.99	4698	1397	1.60								
1.1	4123	1226	1.82								
1.3	3666	1090	2.1								
1.5	3198	951	2.4								
1.7	2795	831	2.7								
1.2	4016	1194	1.01								
1.3	3686	1095	1.10								
1.4	3508	1043	1.15								
1.5	3118	927	1.30								
1.6	2986	888	1.35								
1.7	2731	812	1.48								
1.8	2647	787	1.53								
2.0	2327	692	1.74								
2.3	2035	605	1.99								

R

输出转速	输出扭矩	传动比	使用系数	机型号	极数	输出转速	输出扭矩	传动比	使用系数	机型号	极数
Output speed	Output torque	Ratio	Service factor	Type	Pole	Output speed	Output torque	Ratio	Service factor	Type	Pole
r/min	Nm	i	f _s	Type	p	r/min	Nm	i	f _s	Type	p
0.55kW						0.55kW					
1.5	3151	937	0.89			8.8	562	158.14	1.00		
1.7	2771	824	1.02			10	489	137.67	1.15		
1.9	2479	737	1.14			11	458	128.97	1.23		
2.2	2122	631	1.33			12	405	113.94	1.39		
2.5	1883	560	1.50	R 97R57	4	13	376	105.83	1.50	R 67	4
2.9	1628	484	1.73	RF97R57	4	14	341	95.91	1.66	RF67	4
3.2	1446	430	1.95			16	306	86.11	1.84		
3.7	1275	379	2.2			19	263	74.17	2.1		
4.1	1130	336	2.5			20	248	69.75	2.3		
4.7	995	296	2.8			23	218	61.26	2.6		
5.6	837	249	3.4			24	202	56.89	2.8		
2.6	1766	525	0.83			12	428	120.63	0.99		
2.9	1587	472	0.92			13	379	106.58	1.12		
3.1	1527	454	0.95			14	352	98.99	1.20		
3.5	1345	400	1.08	R 87R57	4	15	319	89.71	1.33		
3.6	1332	396	1.09	RF87R57	4	17	286	80.55	1.48		
3.9	1214	361	1.20			20	246	69.23	1.72		
4.0	1180	351	1.23			21	230	64.85	1.84	R 57	4
4.6	1026	305	1.42			24	203	57.29	2.1	RF57	4
5.1	925	275	0.83			26	189	53.22	2.2		
5.9	794	236	0.97	R 77R37	4	29	171	48.23	2.5		
6.3	743	221	1.04	RF77R37	4	32	154	43.30	2.8		
7.8	599	178	1.29			37	132	37.30	3.2		
2.6	1893	256.89	1.50	R 97	8	40	125	35.07	3.4		
2.8	1775	240.83	1.59	RF97	8	53	93	26.31	4.5		
3.1	1591	215.94	1.77			56	89	24.99	4.8		
2.9	1682	289.60	1.68			63	78	21.93	5.4		
3.3	1492	256.89	1.90	R 97	6	75	66	18.60	6.4		
3.5	1399	240.83	2.0	RF97	6	15	333	93.68	0.85		
3.9	1254	215.94	2.2			16	302	84.90	0.94		
4.8	1029	289.60	2.7			18	271	76.23	1.04		
5.4	912	256.89	3.1	R 97	4	20	243	68.54	1.16		
5.8	855	240.83	3.3	RF97	4	22	228	64.21	1.24		
6.4	767	215.94	3.7			25	202	56.73	1.40		
3.6	1375	246.54	1.06			26	187	52.69	1.51	R 47	4
4.1	1208	216.54	1.21	R 87	6	29	170	47.75	1.66	RF47	4
4.3	1148	205.71	1.27	RF87	6	32	152	42.87	1.85		
4.9	1014	181.77	1.44			38	131	36.93	2.1		
5.7	867	155.34	1.68			40	123	34.73	2.3		
5.6	876	246.54	1.66			47	106	29.88	2.7		
6.4	769	216.54	1.89			52	95	26.74	3.0		
6.8	731	205.71	2.0			60	83	23.28	3.4		
7.6	646	181.77	2.3	R 87	4	64	77	21.81	3.6		
8.9	552	155.34	2.6	RF87	4	23	217	61.18	0.87		
9.8	506	142.41	2.9			25	198	55.76	0.95		
11	444	124.97	3.3			29	171	48.08	1.10		
12	421	118.43	3.5			31	159	44.81	1.18		
13	368	103.65	4.0			35	139	39.17	1.35		
8.3	592	166.59	1.30			38	130	36.72	1.44		
9.5	517	145.67	1.49			43	115	32.40	1.63	R 37	4
10	492	138.39	1.57			48	102	28.73	1.84	RF37	4
11	431	121.42	1.79			57	87	24.42	2.2		
13	366	102.99	2.1			62	79	22.27	2.4		
15	330	92.97	2.3	R 77	4	72	69	19.31	2.7		
17	291	81.80	2.7	RF77	4	77	64	18.05	2.9		
18	274	77.24	2.8			89	55	15.60	3.4		
21	234	65.77	3.3			105	47	13.25	4.0		
						117	42	11.83	4.5		

R

输出转速	输出扭矩	传动比	使用系数	机型号	极数	输出转速	输出扭矩	传动比	使用系数	机型号	极数
Output speed	Output torque	Ratio	Service factor	Type	Pole	Output speed	Output torque	Ratio	Service factor	Type	Pole
r/min	Nm	i	f _s	Type	p	r/min	Nm	i	f _s	Type	p
0.55kW						0.55kW					
35	139	39.25	0.88			320	16	4.35	4.0		
38	131	36.79	0.94			367	14	3.79	4.6		
43	115	32.47	1.06			392	13	3.55	4.9		
48	102	28.78	1.20			443	12	3.14	5.3		
57	87	24.47	1.41			478	11	2.91	5.8		
62	79	22.32	1.54			527	10	2.64	6.6	RX 57	4
72	69	19.35	1.78			586	8.8	2.37	7.4	RXF57	4
77	64	18.08	1.90			681	7.6	2.04	8.6		
89	56	15.63	2.2			724	7.1	1.92	9.1		
105	47	13.28	2.6	R 27	4	842	6.1	1.65	11		
117	42	11.86	2.9	RF27	4	939	5.8	1.48	12		
137	36	10.13	3.2			1069	4.8	1.30	12		
148	33	9.41	3.4								
170	29	8.16	3.8			426	12	3.26	1.24		
182	27	7.63	3.9			456	11	3.05	1.33		
211	23	6.59	4.3			527	10	2.64	1.53	RX 37	4
248	20	5.60	4.7			621	8.3	2.24	1.81	RXF37	4
278	18	5.00	5.0			695	7.4	2.00	2.03		
326	15	4.27	5.4			813	6.3	1.71	2.37		
348	14	4.00	5.6			869	5.9	1.60	2.53		
412	12	3.37	6.2								
0.75kW						0.75kW					
77	64	18.06	1.25			0.30	21596	4709	0.8		
89	55	15.57	1.44			0.33	19179	4182	0.88		
96	52	14.52	1.55			0.52	12185	2657	1.39	R 167R97	4
110	45	12.69	1.77			0.60	10699	2333	1.58	RF167R97	4
117	42	11.89	1.89			0.67	9562	2085	1.77		
132	37	10.50	1.9			0.95	6677	1456	2.5		
149	33	9.31	2.0								
161	31	8.63	2.1	R 17	4	0.43	14804	3228	0.83		
176	28	7.91	2.2	RF17	4	0.49	12992	2833	0.94		
184	27	7.55	2.2			0.54	11717	2555	1.04		
197	25	7.04	2.3			0.63	10140	2211	1.21		
226	22	6.15	2.4			0.71	8947	1951	1.37	R 147R77	4
241	20	5.76	2.6			0.82	7819	1705	1.56	RF147R77	4
273	18	5.09	2.7			0.90	7044	1536	1.73		
308	16	4.51	2.8			1.0	6095	1329	2.0		
363	14	3.83	3.1			1.2	5347	1166	2.3		
0.75kW						0.75kW					
171	30	5.18	2.3			0.67	9507	2073	0.79		
195	26	4.53	2.9	RX 67	6	0.7	8544	1863	0.88		
206	25	4.30	3.0	RXF67	6	0.76	8434	1839	0.89		
235	22	3.77	3.7			0.87	7287	1589	1.03		
						0.9	7273	1586	1.03	R 137R77	4
						0.99	6407	1397	1.17	RF137R77	4
268	19	5.18	3.7			1.0	6237	1360	1.21		
307	17	4.53	4.6			1.1	5632	1228	1.34		
323	16	4.30	4.7			1.2	5623	1226	1.34		
369	14	3.77	5.9			1.3	4999	1090	1.50		
434	12	3.20	7.9			1.5	4361	951	1.72		
481	11	2.89	9.3	RX 67	4	1.7	3811	831	1.97		
547	9.4	2.54	12	RXF67	4	1.9	3348	730	2.2		
579	8.9	2.40	13								
681	7.6	2.04	17			1.3	5022	1095	0.80		
747	6.9	1.86	17			1.4	4783	1043	0.85		
863	6.0	1.61	18			1.5	4251	927	0.95	R 107R77	4
						1.6	4072	888	0.99	RF107R77	4
						1.7	3724	812	1.09		
203	25	4.35	2.5			1.8	3609	787	1.12		
234	22	3.79	2.9			3.9	1637	357	2.5		
249	21	3.55	3.1	RX 57	6	4.4	1435	313	2.8		
282	18	3.14	3.3	RXF57	6						
304	17	2.91	3.7			2.2	2894	631	0.97		
						2.5	2568	560	1.10		
						2.9	2220	484	1.27		
						3.2	1972	430	1.43	R 97R57	4
						3.7	1738	379	1.62	RF97R57	4
						4.1	1541	336	1.83		
						4.7	1357	296	2.1		
						5.6	1142	249	2.5		

输出转速	输出扭矩	传动比	使用系数	机型号	极数	输出转速	输出扭矩	传动比	使用系数	机型号	极数
Output speed	Output torque	Ratio	Service factor	Type	Pole	Output speed	Output torque	Ratio	Service factor	Type	Pole
r/min	Nm	i	f _s	Type	p	r/min	Nm	i	f _s	Type	p
0.75kW						0.75kW					
3.5	1816	396	0.80	R 87R57 RF87R57	4	13	516	106.58	0.82	R 57 RF57	4
3.9	1656	361	0.91			14	479	98.99	0.88		
4.0	1610	351	1.04			15	435	89.71	0.97		
4.6	1399	305	1.19			17	390	80.55	1.08		
4.7	1376	300	1.35			20	335	69.23	1.26		
5.2	1224	267	1.70			21	314	64.85	1.35		
5.4	1174	256	2.0			24	277	57.29	1.52		
5.9	1078	235	2.4			26	258	53.22	1.64		
						29	234	48.23	1.81		
2.8	2445	245.50	1.65	R 107	8	32	210	43.30	2.0		
3.0	2259	226.11	1.81	RF107	8	37	181	37.30	2.3		
3.4	1995	200.87	2.0			40	170	35.07	2.5		
3.1	2138	215.94	1.32	R 97	8	46	146	30.18	2.9		
3.7	1841	185.97	1.53	RF97	8	52	131	26.97	3.2		
4.0	1674	169.06	1.68			53	130	26.31	3.3		
						56	124	24.99	3.4		
3.6	1901	256.89	1.49	R 97	6	63	108	21.93	3.9		
3.8	1782	240.83	1.58	RF97	6	75	92	18.60	4.6		
4.2	1598	215.94	1.76								
4.8	1403	289.60	2.0	R 97 RF97	4	20	332	68.54	0.85	R 47 RF47	4
5.4	1244	256.89	2.3			22	311	64.21	0.91		
5.8	1167	240.83	2.4			25	275	56.73	1.03		
6.4	1046	215.94	2.7			26	255	52.69	1.10		
7.5	901	185.97	3.1			29	231	47.75	1.22		
8.2	819	169.06	3.4			32	208	42.87	1.36		
						38	179	36.93	1.58		
4.2	1602	216.54	0.91	R 87 RF87	6	40	168	34.73	1.68		
4.4	1522	205.71	0.96			47	145	29.88	1.95		
5.0	1345	181.77	1.08			52	130	26.74	2.2		
5.9	1149	155.34	1.27			53	129	26.70	2.2		
6.4	1054	142.41	1.38			59	114	23.59	2.5		
						60	113	23.28	2.5		
5.6	1194	246.54	1.22	R 87 RF87	4	64	106	21.81	2.7	R 37 RF37	4
6.4	1049	216.54	1.39			72	93	19.27	3.0		
6.8	996	205.71	1.46			78	87	17.89	3.1		
7.6	880	181.77	1.65			86	79	16.22	3.3		
8.9	752	155.34	1.94								
9.8	690	142.41	2.1			29	233	48.08	0.81		
11	605	124.97	2.4			31	217	44.81	0.87		
12	574	118.43	2.5			35	190	39.17	0.99		
13	502	103.65	2.9			38	178	36.72	1.06		
15	452	93.38	3.2			43	157	32.40	1.20		
8.3	807	166.59	0.96	R 77 RF77	4	48	139	28.78	0.88	R 27 RF27	4
9.5	706	145.67	1.09			57	119	24.47	1.03		
10	670	138.39	1.15			62	110	22.27	1.71		
11	588	121.42	1.31			72	96	19.31	1.97		
13	499	102.99	1.55			77	89	18.05	2.1		
15	450	92.97	1.71			89	77	15.60	2.4		
17	396	81.80	1.95			105	66	13.25	2.7		
18	375	77.24	2.1			117	59	11.83	2.9		
21	319	65.77	2.4			137	50	10.11	3.2		
25	273	56.38	2.8			147	47	9.47	3.4		
27	247	50.90	3.1								
31	217	44.78	3.6			48	139	28.78	0.88		
33	205	42.29	3.8			57	119	24.47	1.03		
				62	110	22.32	1.11				
11	625	128.97	0.90	R 67 RF67	4	72	96	19.35	1.28	R 27 RF27	4
12	552	113.94	1.02			77	89	18.08	1.37		
13	513	105.83	1.10			89	77	15.63	1.58		
14	465	95.91	1.21			105	66	13.28	1.86		
16	417	86.11	1.35			117	59	11.86	2.1		
19	359	74.17	1.57			137	50	10.13	2.3		
20	338	69.75	1.67			148	47	9.41	2.5		
23	297	61.26	1.90			170	40	8.16	2.7		
24	276	56.89	2.0			182	38	7.63	2.8		
27	250	51.56	2.3			211	33	6.59	3.1		
30	224	46.29	2.5			248	28	5.60	3.4		
						278	25	5.00	3.6		

R

输出转速	输出扭矩	传动比	使用系数	机型号	极数	输出转速	输出扭矩	传动比	使用系数	机型号	极数
Output speed	Output torque	Ratio	Service factor	Type	Pole	Output speed	Output torque	Ratio	Service factor	Type	Pole
r/min	Nm	i	f _s	Type	p	r/min	Nm	i	f _s	Type	p
0.75kW						1.1kW					
77	89	18.06	0.89			0.53	17744	2657	0.95		
89	77	15.57	1.04			0.60	15580	2333	1.09		
96	72	14.52	1.11			0.67	13924	2085	1.22	R 167R97	4
110	63	12.69	1.27			0.75	12535	1877	1.35	RF167R97	4
117	59	11.89	1.36			0.84	11153	1670	1.52		
132	52	10.50	1.41			0.96	9723	1456	1.74		
149	46	9.31	1.47	R 17	4	1.1	8655	1296	2.0		
176	39	7.91	1.48	RF17	4	1.2	7593	1137	2.2		
184	37	7.55	1.57								
197	35	7.04	1.67			0.63	14765	2211	0.83		
226	30	6.15	1.73			0.72	13029	1951	0.94		
241	28	5.76	1.75			0.82	11386	1705	1.07		
273	25	5.09	1.90			0.91	10258	1536	1.19	R 147R77	4
308	22	4.51	2.0			1.1	8875	1329	1.38	RF147R77	4
363	19	3.83	2.2			1.2	7787	1166	1.57		
						1.4	6872	1029	1.78		
201	35	4.53	2.2			1.6	5937	889	2.1		
212	33	4.30	2.3	RX 67	6	1.8	5236	784	2.3		
241	29	3.77	2.8	RXF67	6	2.0	4641	695	2.6		
284	25	3.20	3.8								
268	26	5.18	2.7			1.0	9082	1360	0.83		
307	23	4.53	3.4			1.1	8201	1228	0.92		
323	22	4.30	3.5			1.2	8187	1226	0.92		
369	19	3.77	4.3			1.3	7279	1090	1.03		
434	16	3.20	5.8	RX 67	4	1.3	7212	1080	1.04		
481	15	2.89	6.8	RXF67	4	1.4	6812	1020	1.10	R 137R77	4
547	13	2.54	8.6			1.5	6351	951	1.18	RF137R77	4
579	12	2.40	9.5			1.6	5803	869	1.30		
681	10	2.04	12			1.7	5550	831	1.36		
747	9	1.86	13			1.9	4875	730	1.54		
863	8	1.61	13			2.2	4201	629	1.79		
						2.6	3666	549	2.1		
						2.9	3272	490	2.3		
240	29	3.79	2.2			2.0	4621	692	0.87		
256	27	3.55	2.4			2.3	3994	598	1.01		
290	24	3.14	2.5	RX 57	6	2.6	3539	530	1.14		
313	22	2.91	2.8	RXF57	6	2.9	3199	479	1.26	R 107R77	4
345	20	2.64	3.2			3.4	2711	406	1.49	RF107R77	4
						3.9	2384	357	1.70		
320	22	4.35	2.9			4.5	2090	313	1.93		
367	19	3.79	3.4			5.1	1850	277	2.2		
392	18	3.55	3.6			5.7	1636	245	2.5		
443	16	3.14	3.9								
478	15	2.91	4.3			3.3	2872	430	0.98		
527	13	2.64	4.9	RX 57	4	3.7	2531	379	1.11		
586	12	2.37	5.4	RXF57	4	4.2	2244	336	1.26	R 97R57	4
681	11	2.04	6.3			4.7	1977	296	1.43	RF97R57	4
724	10	1.92	6.7			5.6	1663	249	1.70		
842	9	1.65	7.8			6.0	1563	234	1.80		
939	8	1.48	8.6			6.7	1396	209	2.0		
1069	7	1.30	9.0								
						5.2	1783	267	0.82		
456	15	3.05	0.97			5.5	1710	256	0.85		
527	13	2.64	1.13			6.0	1569	235	0.93	R 87R57	4
621	11	2.24	1.33	RX 37	4	6.1	1543	231	0.94	RF87R57	4
695	10	2.00	1.49	RXF37	4	6.7	1389	208	1.05		
813	9	1.71	1.74			7.2	1302	195	1.12		
869	8	1.60	1.86								
						2.8	3586	245.50	1.13		
						3.0	3283	226.11	1.23	R 107	8
						3.4	2901	200.87	1.39	RF107	8
						4.0	2461	167.29	1.64		

R

输出转速	输出扭矩	传动比	使用系数	机型号	极数	输出转速	输出扭矩	传动比	使用系数	机型号	极数
Output speed	Output torque	Ratio	Service factor	Type	Pole	Output speed	Output torque	Ratio	Service factor	Type	Pole
r/min	Nm	i	f _s	Type	p	r/min	Nm	i	f _s	Type	p
1.1kW						1.1kW					
3.5	2788	256.89	1.02			20	488	69.23	0.87		
3.8	2613	240.83	1.08	R 97	6	22	457	64.85	0.92		
4.2	2343	215.94	1.20	RF97	6	24	404	57.29	1.05		
4.9	2018	185.97	1.39			26	375	53.22	1.13		
						29	340	48.23	1.24		
5.4	1812	256.89	1.56			32	305	43.30	1.39		
5.8	1699	240.83	1.66			38	263	37.30	1.61	R 57	4
6.5	1523	215.94	1.85			40	247	35.07	1.71	RF57	4
7.5	1312	185.97	2.1	R 97	4	46	213	30.18	1.99		
8.3	1192	169.06	2.4	RF97	4	52	190	26.97	2.2		
9.3	1064	150.78	2.7			53	186	26.31	2.3		
11	894	126.75	3.2			56	176	24.99	2.4		
12	822	116.48	3.4			64	155	21.93	2.7		
						75	131	18.60	3.2		
6.5	1527	216.54	0.95			83	118	16.79	3.6		
6.8	1451	205.71	1.00								
7.7	1282	181.77	1.14			29	337	47.75	0.84		
9.0	1096	155.34	1.33			33	302	42.87	0.93		
9.8	1004	142.41	1.45			38	260	36.93	1.08		
11	881	124.97	1.65			40	245	34.73	1.15		
12	835	118.43	1.74	R 87	4	47	211	29.88	1.34		
14	731	103.65	1.99	RF87	4	52	188	26.70	1.50		
15	659	93.38	2.2			59	166	23.59	1.69		
17	578	81.92	2.5			60	164	23.28	1.72		
19	510	72.37	2.9			64	154	21.81	1.83	R 47	4
22	448	63.50	3.3			73	136	19.27	2.0	RF47	4
23	424	60.18	3.4			78	126	17.89	2.2		
27	372	52.67	3.9			86	114	16.22	2.3		
						96	103	14.56	2.4		
12	856	121.42	0.90			112	88	12.54	2.7		
14	726	102.99	1.06			119	83	11.79	2.8		
15	656	92.97	1.18			138	72	10.15	3.0		
17	577	81.80	1.34			154	64	9.07	3.2		
18	545	77.24	1.41								
21	464	65.77	1.66	R 77	4	43	229	32.40	0.82		
25	398	56.38	1.94	RF77	4	49	203	28.73	0.93		
28	359	50.90	2.1			57	172	24.42	1.09		
31	316	44.78	2.4			73	139	19.31	1.35		
33	298	42.29	2.6			78	130	18.05	1.45		
39	254	36.01	3.0			90	112	15.60	1.67		
43	231	32.72	3.3			106	95	13.25	1.87		
						118	85	11.83	2.0	R 37	4
16	607	86.11	0.93			138	73	10.11	2.2	RF37	4
19	523	74.17	1.08			148	68	9.47	2.3		
20	492	69.75	1.15			176	57	7.97	2.6		
23	432	61.26	1.31			210	48	6.67	2.8		
25	401	56.89	1.41			247	41	5.67	3.3		
27	364	51.56	1.55			277	36	5.06	3.5		
30	326	46.29	1.73								
35	281	39.88	1.9	R 67	4	72	139	19.35	0.88		
37	265	37.50	2.0	RF67	4	77	130	18.08	0.94		
43	228	32.27	2.2			90	113	15.63	1.09		
49	203	28.83	2.4			105	96	13.28	1.25		
50	201	28.13	2.5			118	85	11.86	1.42		
52	192	26.72	2.6			138	73	10.13	1.57		
60	169	23.44	3.1			172	59	8.16	1.86	R 27	4
70	143	19.89	3.9			183	55	7.63	1.92	RF27	4
						212	47	6.59	2.1		
						250	40	5.60	2.3		
						280	36	5.00	2.5		
						328	31	4.27	2.7		
						350	29	4.00	2.8		
						415	24	3.37	3.1		

R

输出转速 Output speed r/min	输出扭矩 Output torque Nm	传动比 Ratio i	使用系数 Service factor f _s	机型号 Type Type	极数 Pole p	输出转速 Output speed r/min	输出扭矩 Output torque Nm	传动比 Ratio i	使用系数 Service factor f _s	机型号 Type Type	极数 Pole p
1.1kW						1.5kW					
249	41	5.63	2.5	RX 77	4	1.3	10038	1090	0.75		
262	39	5.35	2.5	RXF77	4	1.4	9393	1020	0.80		
296	35	4.73	3.3			1.5	8758	951	0.86		
						1.6	8003	869	0.94		
201	51	4.53	1.50	RX 67	6	1.7	7653	831	0.98		
212	49	4.30	1.55	RXF67	6	1.9	6723	730	1.12		
241	43	3.77	1.92			2.0	6299	684	1.19	R 137R77	4
						2.2	5792	629	1.30	RF137R77	4
309	33	4.53	2.3			2.4	5479	595	1.37		
326	32	4.30	2.4			2.6	5056	549	1.49		
371	28	3.77	2.9			2.9	4512	490	1.67		
438	24	3.20	4.0			3.3	3941	428	1.91		
484	21	2.89	4.7	RX 67	4	3.7	3444	374	2.2		
551	19	2.54	5.9	RXF67	4	4.4	2919	317	2.6		
583	18	2.40	6.6								
686	15	2.04	8.4			2.6	4827	530	0.84		
753	14	1.86	8.7			2.7	4644	510	0.87		
870	12	1.61	9.1			2.9	4362	479	0.93		
1000	10	1.40	9.5			3.0	4216	463	0.96	R 107R77	4
						3.4	3697	406	1.09	RF107R77	4
						3.9	3251	357	1.24		
240	43	3.79	1.5	RX 57	6	4.5	2850	313	1.42		
256	40	3.55	1.6	RXF57	6						
290	36	3.14	1.7			4.2	3060	336	0.92		
313	33	2.91	1.9			4.7	2696	296	1.05		
345	30	2.64	2.2			5.6	2268	249	1.24	R 97R57	4
						6.0	2131	234	1.32	RF97R57	4
369	28	3.79	2.3			6.7	1903	209	1.48		
394	26	3.55	2.5								
446	23	3.14	2.6			3.1	4413	226.11	0.92		
481	21	2.91	2.9			3.5	3920	200.87	1.03	R 107	8
530	19	2.64	3.3	RX 57	4	4.1	3265	167.29	1.24	RF107	8
591	17	2.37	3.7	RXF57	4	4.4	3045	156.04	1.32		
686	15	2.04	4.3								
729	14	1.92	4.6			3.7	3593	245.50	1.12		
848	12	1.65	5.3			4.1	3309	226.11	1.22		
946	11	1.48	5.9			4.6	2940	200.87	1.37	R 107	6
1077	10	1.30	6.2			5.5	2449	167.29	1.65	RF107	6
						5.8	2304	156.04	1.77		
700	15	2.00	1.02	RX 37	4	6.6	2041	139.47	1.98		
819	13	1.71	1.19	RXF37	4						
875	12	1.60	1.27								
1.5kW						1.5kW					
0.60	21246	2333	0.80			5.4	2417	256.89	1.14		
0.67	18987	2085	0.89			5.8	2316	240.83	1.22		
0.75	17093	1877	0.99			6.5	2077	215.94	1.36		
0.84	15208	1670	1.11	R 167R97	4	7.5	1789	185.97	1.58		
0.96	13259	1456	1.28	RF167R97	4	8.3	1626	169.06	1.73	R 97	4
1.1	11802	1296	1.43			9.3	1450	150.78	1.94	RF97	4
1.2	10354	1137	1.63			11	1219	126.75	2.3		
1.4	9213	1012	1.84			12	1120	116.48	2.5		
						14	995	103.44	2.8		
						15	889	92.47	3.2		
3.2	3934	432	3.1	R 147R87	4						
3.8	3388	373	3.6	RF147R87	4	7.7	1748	181.77	0.83		
						9.0	1494	155.34	0.98		
0.82	15527	1705	0.8			9.8	1370	142.41	1.06		
0.91	13988	1536	0.87			11	1202	124.97	1.21		
1.1	12103	1329	1.01			12	1139	118.43	1.28		
1.2	10618	1166	1.15			14	997	103.65	1.46		
1.4	9371	1029	1.30	R 147R77	4	15	898	93.38	1.62		
1.6	8096	889	1.51	RF147R77	4	17	788	81.92	1.85	R 87	4
1.8	7140	784	1.71			19	696	72.37	2.1	RF87	4
2.0	6329	695	1.93			22	611	63.50	2.4		
2.3	5528	607	2.2			23	579	60.18	2.5		
2.6	4981	547	2.5			27	507	52.67	2.9		
						30	456	47.45	3.2		
						34	400	41.63	3.6		
						38	353	36.73	4.1		

R

输出转速	输出扭矩	传动比	使用系数	机型号	极数	输出转速	输出扭矩	传动比	使用系数	机型号	极数
Output speed	Output torque	Ratio	Service factor	Type	Pole	Output speed	Output torque	Ratio	Service factor	Type	Pole
r/min	Nm	i	f _s	Type	p	r/min	Nm	i	f _s	Type	p
1.5kW						1.5kW					
15	894	92.97	0.86			73	186	19.31	1.01		
17	787	81.80	0.98			78	174	18.05	1.08		
18	743	77.24	1.04			90	150	15.60	1.25		
21	633	65.77	1.22			106	127	13.25	1.40		
25	542	56.38	1.42			118	114	11.83	1.51		
28	490	50.90	1.57			138	97	10.11	1.64		
31	431	44.78	1.79	R 77	4	148	91	9.47	1.72	R 37	4
33	407	42.29	1.90	RF77	4	176	77	7.97	1.91	RF37	4
39	346	36.01	2.2			210	64	6.67	2.1		
43	315	32.72	2.4			247	55	5.67	2.4		
49	273	28.35	2.8			277	49	5.06	2.6		
57	237	24.67	3.1			324	42	4.32	2.9		
60	225	23.37	3.4			346	39	4.05	2.9		
65	206	21.43	3.7			411	33	3.41	3.2		
74	181	18.80	4.1								
23	589	61.26	0.96			90	150	15.63	0.81		
25	547	56.89	1.03			105	128	13.28	0.96		
27	496	51.56	1.14			118	114	11.86	1.06		
30	445	46.29	1.27			138	97	10.13	1.18		
35	384	39.88	1.47			172	78	8.16	1.39		
37	361	37.50	1.56	R 67	4	183	73	7.63	1.43	R 27	4
43	310	32.27	1.82	RF67	4	212	63	6.59	1.57	RF27	4
49	277	28.83	2.0			250	54	5.60	1.73		
50	276	28.13	2.0			280	48	5.00	1.86		
52	262	26.72	2.1			328	41	4.27	1.99		
60	230	23.44	2.4			350	38	4.00	2.1		
70	195	19.89	2.9			415	32	3.37	2.3		
78	176	17.95	3.2								
26	523	53.22	0.8			249	54	5.63	1.91		
29	474	48.23	0.9			262	51	5.35	1.88		
32	425	43.30	1.0			296	45	4.73	2.5		
38	366	37.30	1.15			347	39	4.04	3.5	RX 77	4
40	344	35.07	1.23			378	36	3.70	4.0	RXF77	4
46	296	30.18	1.43			431	31	3.25	5.5		
52	265	26.97	1.60	R 57	4	455	30	3.08	6.1		
53	258	26.31	1.64	RF57	4	519	26	2.70	7.8		
56	245	24.99	1.72			576	23	2.43	8.6		
64	215	21.93	1.96								
75	183	18.60	2.3			309	44	4.53	1.77		
83	165	16.79	2.6			326	41	4.30	1.82		
95	145	14.77	2.8			371	36	3.77	2.3		
100	137	13.95	2.9			438	31	3.20	3.1		
118	117	11.88	3.3			484	28	2.89	3.6	RX 67	4
						551	24	2.54	4.5	RXF67	4
38	355	36.93	0.8			583	23	2.40	5.0		
40	334	34.73	0.84			686	20	2.04	6.4		
47	287	29.88	0.98			753	18	1.86	6.6		
52	257	26.70	1.1			870	15	1.61	6.9		
59	227	23.59	1.2			1000	13	1.40	7.3		
60	224	23.28	1.26								
64	210	21.81	1.34			369	36	3.79	1.78		
73	185	19.27	1.50			394	34	3.55	1.90		
78	172	17.89	1.58			446	30	3.14	2.0		
86	156	16.22	1.66			481	28	2.91	2.3		
96	140	14.56	1.8			530	25	2.64	2.6		
112	121	12.54	1.9	R 47	4	591	23	2.37	2.8	RX 57	4
119	113	11.79	2.0	RF47	4	686	20	2.04	3.3	RXF57	4
138	98	10.15	2.1			729	18	1.92	3.5		
154	87	9.07	2.2			848	16	1.65	4.1		
175	77	8.01	2.3			946	14	1.48	4.5		
180	75	7.76	2.4			1077	13	1.30	4.7		
201	67	6.96	2.5								
233	58	6.00	2.5								
248	54	5.64	2.7								
289	47	4.85	3.0								
323	42	4.34	3.3								
366	37	3.83	3.7								

输出转速	输出扭矩	传动比	使用系数	机型号	极数	输出转速	输出扭矩	传动比	使用系数	机型号	极数
Output speed	Output torque	Ratio	Service factor	Type	Pole	Output speed	Output torque	Ratio	Service factor	Type	Pole
r/min	Nm	i	f _s	Type	p	r/min	Nm	i	f _s	Type	p
2.2kW						2.2kW					
0.85	21991	1670	0.8	R 167R97 RF167R97	4	5.8	3414	245.50	1.18	R 107 RF107	4
0.98	19173	1456	0.88								
1.1	17066	1296	1.0								
1.2	14972	1137	1.1								
1.4	13326	1012	1.27								
1.6	11483	872	1.47								
1.8	10140	770	1.67								
2.1	8744	664	1.9								
2.6	7111	540	1.72	R 147R87 RF147R87	4	5.8	3414	245.50	1.18		
3.1	6084	462	2.0								
3.3	5689	432	2.1								
3.8	4912	373	2.5								
4.3	4346	330	2.8								
1.2	15354	1166	0.80	R 147R77 RF147R77	4	6.6	3003	215.94	0.94		
1.4	13550	1029	0.90								
1.6	11707	889	1.04								
1.8	10324	784	1.18								
2.0	9152	695	1.34								
2.3	7993	607	1.53								
2.6	7203	547	1.70								
3.0	6321	480	1.93								
1.9	9721	730	0.77	R 137R77 RF137R77	4	7.6	2586	185.97	1.09		
2.1	9108	684	0.83								
2.3	8376	629	0.90								
2.4	7923	595	0.95								
2.6	7311	549	1.03								
2.9	6525	490	1.15								
3.3	5699	428	1.32								
3.8	4980	374	1.51								
4.5	4221	317	1.78								
5.0	3808	286	1.97								
5.6	3377	250	2.2								
6.4	2958	219	2.5								
3.9	4822	357	0.84	R 107R77 RF107R77	4	8.4	2351	169.06	1.20		
4.4	4336	321	0.93								
4.5	4228	313	0.96								
5.1	3741	277	1.08								
5.5	3458	256	1.17								
6.7	2809	208	1.44								
6.0	3125	234	0.90			R 97R57 RF97R57	4				
6.7	2791	209	1.01								
3.2	6212	223.34	1.21	R 137 RF137	8	11	1738	124.97	0.84		
3.8	5234	188.16	1.43								
4.1	4851	174.4	1.55								
4.5	4348	156.31	1.73								
5.0	3925	141.12	1.92								
5.5	3565	128.18	2.1								
6.2	3163	113.72	2.4								
6.9	2871	103.2	2.6								
4.7	4220	200.87	0.96	R 107 RF107	6	12	1620	116.48	1.74		
5.6	3515	167.29	1.15								
6.0	3278	156.04	1.23								
6.7	2930	139.47	1.38								
						14	1402	100.82	2.9		
						16	1286	91.16	3.2		
						6.6	3003	215.94	0.94		
						7.6	2586	185.97	1.09		
						8.4	2351	169.06	1.20		
						9.4	2097	150.78	1.34		
						11	1763	126.75	1.60		
						12	1620	116.48	1.74		
						14	1439	103.44	1.96		
						15	1286	92.48	2.2		
						17	1156	83.15	2.4		
						20	1004	72.17	2.8		
						22	906	65.12	3.1		
						24	832	59.84	3.4		
						27	739	53.14	3.8		
						30	661	47.51	4.3		
						11	1738	124.97	0.84		
						12	1647	118.43	0.88		
						14	1442	103.65	1.01		
						15	1299	93.38	1.12		
						17	1139	81.92	1.28		
						20	1007	72.37	1.45		
						22	883	63.50	1.65		
						24	837	60.18	1.74		
						27	733	52.67	1.99		
						30	660	47.45	2.2		
						34	579	41.63	2.5		
						39	511	36.73	2.9		
						41	478	34.34	3.0		
						44	453	32.57	3.2		
						45	434	31.22	3.4		
						51	387	27.81	3.8		
						61	325	23.40	4.5		
						66	299	21.51	4.7		
						22	915	65.77	0.8		
						25	784	56.38	1.0		
						28	708	50.90	1.1		
						32	623	44.78	1.2		
						34	588	42.29	1.31		
						39	501	36.01	1.54		
						43	455	32.72	1.69		
						50	394	28.35	1.95		
						58	343	24.67	2.1		
						61	325	23.37	2.4		
						66	298	21.43	2.6		
						76	261	18.80	2.8		
						80	248	17.82	3.0		
						91	217	15.60	3.2		
						101	195	14.05	3.5		

R

输出转速	输出扭矩	传动比	使用系数	机型号	极数	输出转速	输出扭矩	传动比	使用系数	机型号	极数																																																																																																																																																																																																																																																																																																																																																																																																																																												
Output speed	Output torque	Ratio	Service factor	Type	Pole	Output speed	Output torque	Ratio	Service factor	Type	Pole																																																																																																																																																																																																																																																																																																																																																																																																																																												
r/min	Nm	i	f _s	Type	p	r/min	Nm	i	f _s	Type	p																																																																																																																																																																																																																																																																																																																																																																																																																																												
2.2kW						2.2kW																																																																																																																																																																																																																																																																																																																																																																																																																																																	
36	555	39.88	0.98	R 67 RF67	4	300	69	4.73	1.69	RX 77 RXF77	4																																																																																																																																																																																																																																																																																																																																																																																																																																												
38	522	37.50	1.03			44	449	32.27	1.13			49	401	28.83	1.22	61	326	23.44	1.61	71	277	19.89	2.0	79	250	17.95	2.2	90	220	15.79	2.4	95	207	14.91	2.5	112	177	12.70	2.8	123	160	11.54	2.9	142	139	10.00	3.2	163	121	8.70	3.3	182	108	7.79	3.4	377	55	3.77	1.50	444	46	3.20	2.0	491	42	2.89	2.4	559	37	2.54	3.0	592	35	2.40	3.3	696	30	2.04	4.3	763	27	1.86	4.4	882	23	1.61	4.6	1014	20	1.40	4.8	452	46	3.14	1.34	538	38	2.64	1.69	599	34	2.37	1.89	696	30	2.04	2.2	740	28	1.92	2.3	861	24	1.65	2.7	959	21	1.48	3.0	1092	19	1.30	3.1	74	268	19.27	1.03	R 47 RF47	4	3.0kW						88	226	16.22	1.15	1.2	20417	1137	0.83	R 167R97 RF167R97	4	98	203	14.56	1.23	1.4	18172	1012	0.93	113	174	12.54	1.35	1.6	15658	872	1.08	120	164	11.79	1.40	1.8	13827	770	1.22	140	141	10.15	1.53	2.1	11923	664	1.42	157	126	9.07	1.64	2.8	9158	510	1.85	177	111	8.01	1.73	2.6	9697	540	1.26	R 147R87 RF147R87	4	183	108	7.76	1.42	3.1	8296	462	1.47	204	97	6.96	1.54	3.3	7757	432	1.58	237	83	6.00	1.76	3.8	6698	373	1.82	252	78	5.64	1.86	4.3	5926	330	2.1	293	67	4.85	2.1	5.0	5082	283	2.4	327	60	4.34	2.3	1.6	15963	889	0.8	R 147R77 RF147R77	4	371	53	3.83	2.5	1.8	14078	784	0.87	91	217	15.60	0.87	2.0	12480	695	0.98	107	184	13.25	0.97	2.3	10900	607	1.12	120	165	11.83	1.05	2.6	9822	547	1.24	140	141	10.11	1.14	2.7	9388	517	0.80	R 137R77 RF137R77	4	150	132	9.47	1.19	2.9	8898	490	0.85	178	111	7.97	1.32	3.1	8226	453	0.91	213	93	6.67	1.46	3.3	7772	428	0.97	250	79	5.67	1.69	3.8	6791	374	1.11	281	70	5.06	1.80	4.5	5756	317	1.31	329	60	4.32	2.0	5.0	5193	286	1.45	351	56	4.05	2.0	5.7	4540	250	1.66	416	47	3.41	2.2	6.5	3977	219	1.89	140	141	10.13	0.81	5.6	4798	253	0.84	R 107R77 RF107R77	4	215	92	6.59	1.09	5.8	4647	245	0.87	254	78	5.60	1.19	6.8	3945	208	1.02	284	70	5.00	1.28	7.8	3433	181	1.18	333	59	4.27	1.38					355	56	4.00	1.44					421	47	3.37	1.58																																		
44	449	32.27	1.13			49	401	28.83	1.22			61	326	23.44	1.61	71	277	19.89	2.0	79	250	17.95	2.2	90	220	15.79	2.4	95	207	14.91	2.5	112	177	12.70	2.8	123	160	11.54	2.9	142	139	10.00	3.2	163	121	8.70	3.3	182	108	7.79	3.4	377	55	3.77	1.50	444	46	3.20	2.0	491	42	2.89	2.4	559	37	2.54	3.0	592	35	2.40	3.3	696	30	2.04	4.3	763	27	1.86	4.4	882	23	1.61	4.6	1014	20	1.40	4.8	452	46	3.14	1.34	538	38	2.64	1.69	599	34	2.37	1.89	696	30	2.04	2.2	740	28	1.92	2.3	861	24	1.65	2.7	959	21	1.48	3.0	1092	19	1.30	3.1	74	268	19.27	1.03	R 47 RF47	4	3.0kW						88	226	16.22	1.15	1.2	20417	1137	0.83	R 167R97 RF167R97	4	98	203			14.56	1.23	1.4	18172	1012	0.93	113	174	12.54	1.35	1.6	15658	872	1.08	120	164	11.79	1.40	1.8	13827	770	1.22	140	141	10.15	1.53	2.1	11923	664	1.42	157	126	9.07	1.64	2.8	9158	510	1.85	177	111	8.01	1.73	2.6	9697	540	1.26	R 147R87 RF147R87	4			183	108	7.76	1.42	3.1	8296	462	1.47	204	97	6.96	1.54	3.3	7757	432	1.58	237	83	6.00	1.76	3.8	6698	373	1.82	252	78	5.64	1.86	4.3	5926	330	2.1	293	67	4.85	2.1	5.0	5082	283	2.4	327	60	4.34	2.3	1.6	15963	889	0.8			R 147R77 RF147R77	4	371	53	3.83	2.5	1.8	14078	784	0.87	91	217	15.60	0.87	2.0	12480	695	0.98	107	184	13.25	0.97	2.3	10900	607	1.12	120	165	11.83	1.05	2.6	9822	547	1.24	140	141	10.11	1.14	2.7	9388			517	0.80	R 137R77 RF137R77	4	150	132	9.47	1.19	2.9	8898	490	0.85	178	111	7.97	1.32	3.1	8226	453	0.91	213	93	6.67	1.46	3.3	7772	428	0.97	250	79	5.67	1.69	3.8	6791	374	1.11	281	70	5.06	1.80	4.5	5756	317	1.31	329	60	4.32	2.0	5.0	5193	286	1.45	351	56	4.05	2.0	5.7	4540	250	1.66	416	47	3.41	2.2	6.5	3977	219	1.89	140	141	10.13	0.81			5.6	4798	253	0.84	R 107R77 RF107R77	4	215	92	6.59	1.09	5.8	4647	245	0.87	254	78	5.60	1.19	6.8	3945	208	1.02	284	70	5.00	1.28	7.8	3433	181	1.18	333	59	4.27	1.38					355	56	4.00	1.44					421	47	3.37	1.58																												
49	401	28.83	1.22			61	326	23.44	1.61			71	277	19.89	2.0	79	250	17.95	2.2	90	220	15.79	2.4	95	207	14.91	2.5	112	177	12.70	2.8	123	160	11.54	2.9	142	139	10.00	3.2	163	121	8.70	3.3	182	108	7.79	3.4	377	55	3.77	1.50	444	46	3.20	2.0	491	42	2.89	2.4	559	37	2.54	3.0	592	35	2.40	3.3	696	30	2.04	4.3	763	27	1.86	4.4	882	23	1.61	4.6	1014	20	1.40	4.8	452	46	3.14	1.34	538	38	2.64	1.69	599	34	2.37	1.89	696	30	2.04	2.2	740	28	1.92	2.3	861	24	1.65	2.7	959	21	1.48	3.0	1092	19	1.30	3.1	74	268	19.27	1.03	R 47 RF47	4	3.0kW								88	226	16.22	1.15	1.2	20417	1137	0.83	R 167R97 RF167R97	4			98	203			14.56	1.23	1.4	18172	1012	0.93	113	174	12.54	1.35	1.6	15658	872	1.08	120	164	11.79	1.40	1.8	13827	770	1.22	140	141	10.15	1.53	2.1	11923	664	1.42	157	126	9.07	1.64	2.8	9158	510	1.85	177	111	8.01	1.73	2.6	9697	540	1.26					R 147R87 RF147R87	4	183	108	7.76	1.42	3.1	8296	462	1.47	204	97	6.96	1.54	3.3	7757	432	1.58	237	83	6.00	1.76	3.8	6698	373	1.82	252	78	5.64	1.86	4.3	5926	330	2.1	293	67	4.85	2.1	5.0	5082	283	2.4	327	60	4.34	2.3	1.6	15963					889	0.8	R 147R77 RF147R77	4	371	53	3.83	2.5	1.8	14078	784	0.87	91	217	15.60	0.87	2.0	12480	695	0.98	107	184	13.25	0.97	2.3	10900	607	1.12	120	165	11.83	1.05	2.6	9822	547	1.24	140	141			10.11	1.14			2.7	9388	517	0.80	R 137R77 RF137R77	4	150	132	9.47	1.19	2.9	8898	490	0.85	178	111	7.97	1.32	3.1	8226	453	0.91	213	93	6.67	1.46	3.3	7772	428	0.97	250	79	5.67	1.69	3.8	6791	374	1.11	281	70	5.06	1.80	4.5	5756	317	1.31	329	60	4.32	2.0	5.0	5193	286	1.45	351	56	4.05	2.0	5.7	4540	250	1.66	416	47	3.41	2.2	6.5	3977			219	1.89	140	141			10.13	0.81	5.6	4798	253	0.84	R 107R77 RF107R77	4	215	92	6.59	1.09	5.8	4647	245	0.87	254	78	5.60	1.19	6.8	3945	208	1.02	284	70	5.00	1.28	7.8	3433	181	1.18	333	59	4.27	1.38					355	56	4.00	1.44					421	47	3.37	1.58																				
61	326	23.44	1.61			71	277	19.89	2.0			79	250	17.95	2.2	90	220	15.79	2.4	95	207	14.91	2.5	112	177	12.70	2.8	123	160	11.54	2.9	142	139	10.00	3.2	163	121	8.70	3.3	182	108	7.79	3.4	377	55	3.77	1.50	444	46	3.20	2.0	491	42	2.89	2.4	559	37	2.54	3.0	592	35	2.40	3.3	696	30	2.04	4.3	763	27	1.86	4.4	882	23	1.61	4.6	1014	20	1.40	4.8	452	46	3.14	1.34	538	38	2.64	1.69	599	34	2.37	1.89	696	30	2.04	2.2	740	28	1.92	2.3	861	24	1.65	2.7	959	21	1.48	3.0	1092	19	1.30	3.1	74	268	19.27	1.03	R 47 RF47	4	3.0kW								88	226			16.22	1.15	1.2	20417	1137	0.83	R 167R97 RF167R97	4					98	203			14.56	1.23	1.4	18172	1012	0.93	113	174	12.54	1.35	1.6	15658	872	1.08	120	164	11.79	1.40	1.8	13827	770	1.22	140	141	10.15	1.53	2.1	11923	664	1.42	157	126	9.07	1.64	2.8	9158	510	1.85	177	111	8.01	1.73	2.6	9697	540	1.26							R 147R87 RF147R87	4	183	108	7.76	1.42	3.1	8296	462	1.47	204	97	6.96	1.54	3.3	7757	432	1.58	237	83	6.00	1.76	3.8	6698	373	1.82	252	78	5.64	1.86	4.3	5926	330	2.1	293	67	4.85	2.1	5.0	5082	283	2.4	327	60	4.34	2.3					1.6	15963			889	0.8	R 147R77 RF147R77	4	371	53	3.83	2.5	1.8	14078	784	0.87	91	217	15.60	0.87	2.0	12480	695	0.98	107	184	13.25	0.97	2.3	10900	607	1.12	120	165	11.83	1.05	2.6	9822			547	1.24			140	141	10.11	1.14			2.7	9388	517	0.80	R 137R77 RF137R77	4	150	132	9.47	1.19	2.9	8898	490	0.85	178	111	7.97	1.32	3.1	8226	453	0.91	213	93	6.67	1.46	3.3	7772	428	0.97	250	79	5.67	1.69	3.8	6791	374	1.11	281	70	5.06	1.80	4.5	5756	317	1.31	329	60	4.32	2.0	5.0	5193	286	1.45	351	56	4.05	2.0	5.7	4540	250	1.66			416	47	3.41	2.2			6.5	3977	219	1.89	140	141			10.13	0.81	5.6	4798	253	0.84	R 107R77 RF107R77	4	215	92	6.59	1.09	5.8	4647	245	0.87	254	78	5.60	1.19	6.8	3945	208	1.02	284	70	5.00	1.28	7.8	3433	181	1.18	333	59	4.27	1.38					355	56	4.00	1.44					421	47	3.37	1.58												
71	277	19.89	2.0			79	250	17.95	2.2			90	220	15.79	2.4	95	207	14.91	2.5	112	177	12.70	2.8	123	160	11.54	2.9	142	139	10.00	3.2	163	121	8.70	3.3	182	108	7.79	3.4	377	55	3.77	1.50	444	46	3.20	2.0	491	42	2.89	2.4	559	37	2.54	3.0	592	35	2.40	3.3	696	30	2.04	4.3	763	27	1.86	4.4	882	23	1.61	4.6	1014	20	1.40	4.8	452	46	3.14	1.34	538	38	2.64	1.69	599	34	2.37	1.89	696	30	2.04	2.2	740	28	1.92	2.3	861	24	1.65	2.7	959	21	1.48	3.0	1092	19	1.30	3.1	74	268	19.27	1.03	R 47 RF47	4	3.0kW								88	226			16.22	1.15			1.2	20417	1137	0.83	R 167R97 RF167R97	4							98	203			14.56	1.23	1.4	18172	1012	0.93	113	174	12.54	1.35	1.6	15658	872	1.08	120	164	11.79	1.40	1.8	13827	770	1.22	140	141	10.15	1.53	2.1	11923	664	1.42	157	126	9.07	1.64	2.8	9158	510	1.85	177	111	8.01	1.73	2.6	9697	540	1.26									R 147R87 RF147R87	4	183	108	7.76	1.42	3.1	8296	462	1.47	204	97	6.96	1.54	3.3	7757	432	1.58	237	83	6.00	1.76	3.8	6698	373	1.82	252	78	5.64	1.86	4.3	5926	330	2.1	293	67	4.85	2.1	5.0	5082	283	2.4	327	60					4.34	2.3			1.6	15963			889	0.8	R 147R77 RF147R77	4	371	53	3.83	2.5	1.8	14078	784	0.87	91	217	15.60	0.87	2.0	12480	695	0.98	107	184	13.25	0.97	2.3	10900	607	1.12	120	165			11.83	1.05			2.6	9822	547	1.24			140	141	10.11	1.14			2.7	9388	517	0.80	R 137R77 RF137R77	4	150	132	9.47	1.19	2.9	8898	490	0.85	178	111	7.97	1.32	3.1	8226	453	0.91	213	93	6.67	1.46	3.3	7772	428	0.97	250	79	5.67	1.69	3.8	6791	374	1.11	281	70	5.06	1.80	4.5	5756	317	1.31	329	60	4.32	2.0	5.0	5193	286	1.45	351	56			4.05	2.0	5.7	4540			250	1.66	416	47	3.41	2.2			6.5	3977	219	1.89	140	141			10.13	0.81	5.6	4798	253	0.84	R 107R77 RF107R77	4	215	92	6.59	1.09	5.8	4647	245	0.87	254	78	5.60	1.19	6.8	3945	208	1.02	284	70	5.00	1.28	7.8	3433	181	1.18	333	59	4.27	1.38					355	56	4.00	1.44					421	47	3.37	1.58				
79	250	17.95	2.2			90	220	15.79	2.4			95	207	14.91	2.5	112	177	12.70	2.8	123	160	11.54	2.9	142	139	10.00	3.2	163	121	8.70	3.3	182	108	7.79	3.4	377	55	3.77	1.50	444	46	3.20	2.0	491	42	2.89	2.4	559	37	2.54	3.0	592	35	2.40	3.3	696	30	2.04	4.3	763	27	1.86	4.4	882	23	1.61	4.6	1014	20	1.40	4.8	452	46	3.14	1.34	538	38	2.64	1.69	599	34	2.37	1.89	696	30	2.04	2.2	740	28	1.92	2.3	861	24	1.65	2.7	959	21	1.48	3.0	1092	19	1.30	3.1	74	268	19.27	1.03	R 47 RF47	4	3.0kW								88	226			16.22	1.15			1.2	20417			1137	0.83	R 167R97 RF167R97	4									98	203			14.56	1.23	1.4	18172	1012	0.93	113	174	12.54	1.35	1.6	15658	872	1.08	120	164	11.79	1.40	1.8	13827	770	1.22	140	141	10.15	1.53	2.1	11923	664	1.42	157	126	9.07	1.64	2.8	9158	510	1.85	177	111	8.01	1.73	2.6	9697	540	1.26											R 147R87 RF147R87	4	183	108	7.76	1.42	3.1	8296	462	1.47	204	97	6.96	1.54	3.3	7757	432	1.58	237	83	6.00	1.76	3.8	6698	373	1.82	252	78	5.64	1.86	4.3	5926	330	2.1	293	67	4.85	2.1	5.0	5082	283	2.4					327	60			4.34	2.3			1.6	15963			889	0.8	R 147R77 RF147R77	4	371	53	3.83	2.5	1.8	14078	784	0.87	91	217	15.60	0.87	2.0	12480	695	0.98	107	184	13.25	0.97	2.3	10900			607	1.12			120	165	11.83	1.05			2.6	9822	547	1.24			140	141	10.11	1.14			2.7	9388	517	0.80	R 137R77 RF137R77	4	150	132	9.47	1.19	2.9	8898	490	0.85	178	111	7.97	1.32	3.1	8226	453	0.91	213	93	6.67	1.46	3.3	7772	428	0.97	250	79	5.67	1.69	3.8	6791	374	1.11	281	70	5.06	1.80	4.5	5756	317	1.31	329	60	4.32	2.0	5.0	5193	286	1.45	351	56			4.05	2.0	5.7	4540	250	1.66			416	47	3.41	2.2	6.5	3977			219	1.89	140	141	10.13	0.81			5.6	4798	253	0.84	R 107R77 RF107R77	4	215	92	6.59	1.09	5.8	4647	245	0.87	254	78	5.60	1.19	6.8	3945	208	1.02	284	70	5.00	1.28	7.8	3433	181	1.18	333	59	4.27	1.38					355	56	4.00	1.44					421	47
90	220	15.79	2.4			95	207	14.91	2.5			112	177	12.70	2.8	123	160	11.54	2.9	142	139	10.00	3.2	163	121	8.70	3.3	182	108	7.79	3.4	377	55	3.77	1.50	444	46	3.20	2.0	491	42	2.89	2.4	559	37	2.54	3.0	592	35	2.40	3.3	696	30	2.04	4.3	763	27	1.86	4.4	882	23	1.61	4.6	1014	20	1.40	4.8	452	46	3.14	1.34	538	38	2.64	1.69	599	34	2.37	1.89	696	30	2.04	2.2	740	28	1.92	2.3	861	24	1.65	2.7	959	21	1.48	3.0	1092	19	1.30	3.1	74	268	19.27	1.03	R 47 RF47	4	3.0kW								88	226			16.22	1.15			1.2	20417			1137	0.83			R 167R97 RF167R97	4											98	203	14.56	1.23	1.4	18172	1012	0.93	113	174	12.54	1.35	1.6	15658	872	1.08	120	164	11.79	1.40	1.8	13827	770	1.22	140	141	10.15	1.53	2.1	11923	664	1.42	157	126	9.07	1.64	2.8	9158	510	1.85	177	111	8.01	1.73	2.6	9697	540	1.26	R 147R87 RF147R87	4			183	108									7.76	1.42	3.1	8296	462	1.47	204	97	6.96	1.54	3.3	7757	432	1.58	237	83	6.00	1.76	3.8	6698	373	1.82	252	78	5.64	1.86	4.3	5926	330	2.1	293	67	4.85	2.1	5.0	5082	283	2.4	327	60	4.34	2.3			1.6	15963			889	0.8			R 147R77 RF147R77	4			371	53			3.83	2.5	1.8	14078	784	0.87	91	217	15.60	0.87	2.0	12480	695	0.98	107	184	13.25	0.97	2.3	10900	607	1.12			120	165			11.83	1.05	2.6	9822			547	1.24	140	141			10.11	1.14	2.7	9388			517	0.80	R 137R77 RF137R77	4			150	132	9.47	1.19	2.9	8898	490	0.85	178	111	7.97	1.32	3.1	8226	453	0.91	213	93	6.67	1.46	3.3	7772	428	0.97	250	79	5.67	1.69	3.8	6791	374	1.11	281	70	5.06	1.80	4.5	5756	317	1.31	329	60	4.32	2.0	5.0	5193	286	1.45	351	56	4.05	2.0	5.7	4540	250	1.66	416	47			3.41	2.2	6.5	3977	219	1.89			140	141	10.13	0.81	5.6	4798			253	0.84	R 107R77 RF107R77	4			215	92	6.59	1.09	5.8	4647	245	0.87	254	78	5.60	1.19	6.8	3945	208	1.02	284	70	5.00	1.28	7.8	3433	181	1.18	333	59	4.27	1.38					355	56	4.00	1.44					421	47
95	207	14.91	2.5			112	177	12.70	2.8			123	160	11.54	2.9	142	139	10.00	3.2	163	121	8.70	3.3	182	108	7.79	3.4	377	55	3.77	1.50	444	46	3.20	2.0	491	42	2.89	2.4	559	37	2.54	3.0	592	35	2.40	3.3	696	30	2.04	4.3	763	27	1.86	4.4	882	23	1.61	4.6	1014	20	1.40	4.8	452	46	3.14	1.34	538	38	2.64	1.69	599	34	2.37	1.89	696	30	2.04	2.2	740	28	1.92	2.3	861	24	1.65	2.7	959	21	1.48	3.0	1092	19	1.30	3.1	74	268	19.27	1.03	R 47 RF47	4	3.0kW								88	226			16.22	1.15			1.2	20417			1137	0.83			R 167R97 RF167R97	4													98	203	14.56	1.23	1.4	18172	1012	0.93	113	174	12.54	1.35	1.6	15658	872	1.08	120	164	11.79	1.40	1.8	13827	770	1.22	140	141	10.15	1.53	2.1	11923	664	1.42	157	126	9.07	1.64	2.8	9158	510	1.85	177	111	8.01	1.73	2.6	9697	540	1.26	R 147R87 RF147R87	4			183	108	7.76	1.42									3.1	8296	462	1.47	204	97	6.96	1.54	3.3	7757	432	1.58	237	83	6.00	1.76	3.8	6698	373	1.82	252	78	5.64	1.86	4.3	5926	330	2.1	293	67	4.85	2.1	5.0	5082	283	2.4	327	60	4.34	2.3	1.6	15963	889	0.8	R 147R77 RF147R77	4			371	53							3.83	2.5			1.8	14078	784	0.87	91	217	15.60	0.87	2.0	12480	695	0.98	107	184	13.25	0.97	2.3	10900	607	1.12	120	165			11.83	1.05			2.6	9822	547	1.24			140	141	10.11	1.14			2.7	9388	517	0.80			R 137R77 RF137R77	4					150	132	9.47	1.19	2.9	8898	490	0.85	178	111	7.97	1.32	3.1	8226	453	0.91	213	93	6.67	1.46	3.3	7772	428	0.97	250	79	5.67	1.69	3.8	6791	374	1.11	281	70	5.06	1.80	4.5	5756	317	1.31	329	60	4.32	2.0	5.0	5193	286	1.45	351	56	4.05	2.0	5.7	4540	250	1.66	416	47	3.41	2.2	6.5	3977	219	1.89	140	141			10.13	0.81	5.6	4798	253	0.84			R 107R77 RF107R77	4					215	92	6.59	1.09	5.8	4647	245	0.87	254	78	5.60	1.19	6.8	3945	208	1.02	284	70	5.00	1.28	7.8	3433	181	1.18	333	59	4.27	1.38					355	56	4.00	1.44					421	47
112	177	12.70	2.8			123	160	11.54	2.9			142	139	10.00	3.2	163	121	8.70	3.3	182	108	7.79	3.4	377	55	3.77	1.50	444	46	3.20	2.0	491	42	2.89	2.4	559	37	2.54	3.0	592	35	2.40	3.3	696	30	2.04	4.3	763	27	1.86	4.4	882	23	1.61	4.6	1014	20	1.40	4.8	452	46	3.14	1.34	538	38	2.64	1.69	599	34	2.37	1.89	696	30	2.04	2.2	740	28	1.92	2.3	861	24	1.65	2.7	959	21	1.48	3.0	1092	19	1.30	3.1	74	268	19.27	1.03	R 47 RF47	4	3.0kW								88	226			16.22	1.15			1.2	20417			1137	0.83			R 167R97 RF167R97	4															98	203	14.56	1.23	1.4	18172	1012	0.93	113	174	12.54	1.35	1.6	15658	872	1.08	120	164	11.79	1.40	1.8	13827	770	1.22	140	141	10.15	1.53	2.1	11923	664	1.42	157	126	9.07	1.64	2.8	9158	510	1.85	177	111	8.01	1.73	2.6	9697	540	1.26	R 147R87 RF147R87	4					183	108	7.76	1.42	3.1	8296							462	1.47	204	97	6.96	1.54	3.3	7757	432	1.58	237	83	6.00	1.76	3.8	6698	373	1.82	252	78	5.64	1.86	4.3	5926	330	2.1	293	67	4.85	2.1	5.0	5082	283	2.4	327	60	4.34	2.3	1.6	15963	889	0.8	R 147R77 RF147R77	4			371	53	3.83	2.5							1.8	14078			784	0.87	91	217	15.60	0.87	2.0	12480	695	0.98	107	184	13.25	0.97	2.3	10900	607	1.12	120	165	11.83	1.05			2.6	9822			547	1.24	140	141			10.11	1.14	2.7	9388			517	0.80	R 137R77 RF137R77	4									150	132	9.47	1.19	2.9	8898	490	0.85	178	111	7.97	1.32	3.1	8226	453	0.91	213	93	6.67	1.46	3.3	7772	428	0.97	250	79	5.67	1.69	3.8	6791	374	1.11	281	70	5.06	1.80	4.5	5756	317	1.31	329	60	4.32	2.0	5.0	5193	286	1.45	351	56	4.05	2.0	5.7	4540	250	1.66	416	47	3.41	2.2	6.5	3977	219	1.89	140	141	10.13	0.81	5.6	4798	253	0.84	R 107R77 RF107R77	4									215	92	6.59	1.09	5.8	4647	245	0.87	254	78	5.60	1.19	6.8	3945	208	1.02	284	70	5.00	1.28	7.8	3433	181	1.18	333	59	4.27	1.38					355	56	4.00	1.44					421	47
123	160	11.54	2.9			142	139	10.00	3.2	163	121	8.70	3.3	182	108	7.79	3.4	377	55	3.77	1.50	444	46	3.20	2.0	491	42	2.89	2.4	559	37	2.54	3.0	592	35	2.40	3.3	696	30	2.04	4.3	763	27	1.86	4.4	882	23	1.61	4.6	1014	20	1.40	4.8	452	46	3.14	1.34	538	38	2.64	1.69	599	34	2.37	1.89	696	30	2.04	2.2	740	28	1.92	2.3	861	24	1.65	2.7	959	21	1.48	3.0	1092	19	1.30	3.1	74	268	19.27	1.03	R 47 RF47	4	3.0kW						88	226			16.22	1.15			1.2	20417			1137	0.83			R 167R97 RF167R97	4			98	203																	14.56	1.23	1.4	18172	1012	0.93	113	174	12.54	1.35	1.6	15658	872	1.08	120	164	11.79	1.40	1.8	13827	770	1.22	140	141	10.15	1.53	2.1	11923	664	1.42	157	126	9.07	1.64	2.8	9158	510	1.85	177	111	8.01	1.73	2.6	9697	540	1.26	R 147R87 RF147R87	4	183	108							7.76	1.42	3.1	8296	462	1.47	204	97					6.96	1.54	3.3	7757	432	1.58	237	83	6.00	1.76	3.8	6698	373	1.82	252	78	5.64	1.86	4.3	5926	330	2.1	293	67	4.85	2.1	5.0	5082	283	2.4	327	60	4.34	2.3	1.6	15963	889	0.8	R 147R77 RF147R77	4	371	53					3.83	2.5	1.8	14078	784	0.87					91	217			15.60	0.87	2.0	12480	695	0.98	107	184	13.25	0.97	2.3	10900	607	1.12	120	165	11.83	1.05	2.6	9822	547	1.24			140	141			10.11	1.14	2.7	9388			517	0.80	R 137R77 RF137R77	4			150	132											9.47	1.19	2.9	8898	490	0.85	178	111	7.97	1.32	3.1	8226	453	0.91	213	93	6.67	1.46	3.3	7772	428	0.97	250	79	5.67	1.69	3.8	6791	374	1.11	281	70	5.06	1.80	4.5	5756	317	1.31	329	60	4.32	2.0	5.0	5193	286	1.45	351	56	4.05	2.0	5.7	4540	250	1.66	416	47	3.41	2.2	6.5	3977	219	1.89	140	141	10.13	0.81	5.6	4798	253	0.84	R 107R77 RF107R77	4			215	92							6.59	1.09	5.8	4647	245	0.87	254	78	5.60	1.19	6.8	3945	208	1.02	284	70	5.00	1.28	7.8	3433	181	1.18	333	59	4.27	1.38					355	56	4.00	1.44					421	47	3.37	1.58
142	139	10.00	3.2			163	121	8.70	3.3	182	108	7.79	3.4	377	55	3.77	1.50	444	46	3.20	2.0	491	42	2.89	2.4	559	37	2.54	3.0	592	35	2.40	3.3	696	30	2.04	4.3	763	27	1.86	4.4	882	23	1.61	4.6	1014	20	1.40	4.8	452	46	3.14	1.34	538	38	2.64	1.69	599	34	2.37	1.89	696	30	2.04	2.2	740	28	1.92	2.3	861	24	1.65	2.7	959	21	1.48	3.0	1092	19	1.30	3.1	74	268	19.27	1.03	R 47 RF47	4	3.0kW						88	226			16.22	1.15			1.2	20417			1137	0.83			R 167R97 RF167R97	4							98	203															14.56	1.23	1.4	18172	1012	0.93	113	174	12.54	1.35	1.6	15658	872	1.08	120	164	11.79	1.40	1.8	13827	770	1.22	140	141	10.15	1.53	2.1	11923	664	1.42	157	126	9.07	1.64	2.8	9158	510	1.85	177	111	8.01	1.73	2.6	9697	540	1.26	R 147R87 RF147R87	4			183	108							7.76	1.42	3.1	8296	462	1.47	204	97	6.96	1.54			3.3	7757	432	1.58	237	83	6.00	1.76	3.8	6698	373	1.82	252	78	5.64	1.86	4.3	5926	330	2.1	293	67	4.85	2.1	5.0	5082	283	2.4	327	60	4.34	2.3	1.6	15963	889	0.8	R 147R77 RF147R77	4			371	53					3.83	2.5	1.8	14078	784	0.87			91	217	15.60	0.87			2.0	12480	695	0.98	107	184	13.25	0.97	2.3	10900	607	1.12	120	165	11.83	1.05	2.6	9822	547	1.24	140	141	10.11	1.14	2.7	9388			517	0.80	R 137R77 RF137R77	4			150	132					9.47	1.19											2.9	8898	490	0.85	178	111	7.97	1.32	3.1	8226	453	0.91	213	93	6.67	1.46	3.3	7772	428	0.97	250	79	5.67	1.69	3.8	6791	374	1.11	281	70	5.06	1.80	4.5	5756	317	1.31	329	60	4.32	2.0	5.0	5193	286	1.45	351	56	4.05	2.0	5.7	4540	250	1.66	416	47	3.41	2.2	6.5	3977	219	1.89	140	141	10.13	0.81	5.6	4798	253	0.84	R 107R77 RF107R77	4					215	92					6.59	1.09	5.8	4647	245	0.87	254	78	5.60	1.19	6.8	3945	208	1.02	284	70	5.00	1.28	7.8	3433	181	1.18	333	59	4.27	1.38					355	56	4.00	1.44					421	47	3.37	1.58		
163	121	8.70	3.3			182	108	7.79	3.4	377	55	3.77	1.50	444	46	3.20	2.0	491	42	2.89	2.4	559	37	2.54	3.0	592	35	2.40	3.3	696	30	2.04	4.3	763	27	1.86	4.4	882	23	1.61	4.6	1014	20	1.40	4.8	452	46	3.14	1.34	538	38	2.64	1.69	599	34	2.37	1.89	696	30	2.04	2.2	740	28	1.92	2.3	861	24	1.65	2.7	959	21	1.48	3.0	1092	19	1.30	3.1	74	268	19.27	1.03	R 47 RF47	4	3.0kW								88	226	16.22	1.15			1.2	20417			1137	0.83			R 167R97 RF167R97	4											98	203													14.56	1.23	1.4	18172	1012	0.93	113	174	12.54	1.35	1.6	15658	872	1.08	120	164	11.79	1.40	1.8	13827	770	1.22	140	141	10.15	1.53	2.1	11923	664	1.42	157	126	9.07	1.64	2.8	9158	510	1.85	177	111	8.01	1.73	2.6	9697	540	1.26	R 147R87 RF147R87	4					183	108							7.76	1.42	3.1	8296	462	1.47	204	97	6.96	1.54	3.3	7757	432	1.58	237	83	6.00	1.76	3.8	6698	373	1.82	252	78	5.64	1.86	4.3	5926	330	2.1	293	67	4.85	2.1	5.0	5082	283	2.4	327	60	4.34	2.3	1.6	15963	889	0.8	R 147R77 RF147R77	4					371	53					3.83	2.5	1.8	14078	784	0.87			91	217	15.60	0.87	2.0	12480	695	0.98	107	184	13.25	0.97	2.3	10900	607	1.12	120	165	11.83	1.05	2.6	9822	547	1.24	140	141	10.11	1.14	2.7	9388	517	0.80	R 137R77 RF137R77	4	150	132					9.47	1.19					2.9	8898											490	0.85	178	111	7.97	1.32	3.1	8226	453	0.91	213	93	6.67	1.46	3.3	7772	428	0.97	250	79	5.67	1.69	3.8	6791	374	1.11	281	70	5.06	1.80	4.5	5756	317	1.31	329	60	4.32	2.0	5.0	5193	286	1.45	351	56	4.05	2.0	5.7	4540	250	1.66	416	47	3.41	2.2	6.5	3977	219	1.89	140	141	10.13	0.81	5.6	4798	253	0.84	R 107R77 RF107R77	4							215	92			6.59	1.09	5.8	4647	245	0.87	254	78	5.60	1.19	6.8	3945	208	1.02	284	70	5.00	1.28	7.8	3433	181	1.18	333	59	4.27	1.38					355	56	4.00	1.44					421	47	3.37	1.58				
182	108	7.79	3.4			377	55	3.77	1.50	444	46	3.20	2.0	491	42	2.89	2.4	559	37	2.54	3.0	592	35	2.40	3.3	696	30	2.04	4.3	763	27	1.86	4.4	882	23	1.61	4.6	1014	20	1.40	4.8	452	46	3.14	1.34	538	38	2.64	1.69	599	34	2.37	1.89	696	30	2.04	2.2	740	28	1.92	2.3	861	24	1.65	2.7	959	21	1.48	3.0	1092	19	1.30	3.1	74	268	19.27	1.03	R 47 RF47	4	3.0kW								88	226			16.22	1.15	1.2	20417			1137	0.83			R 167R97 RF167R97	4															98	203											14.56	1.23	1.4	18172	1012	0.93	113	174	12.54	1.35	1.6	15658	872	1.08	120	164	11.79	1.40	1.8	13827	770	1.22	140	141	10.15	1.53	2.1	11923	664	1.42	157	126	9.07	1.64	2.8	9158	510	1.85	177	111	8.01	1.73	2.6	9697	540	1.26	R 147R87 RF147R87	4							183	108					7.76	1.42	3.1	8296	462	1.47	204	97	6.96	1.54	3.3	7757	432	1.58	237	83	6.00	1.76	3.8	6698	373	1.82	252	78	5.64	1.86	4.3	5926	330	2.1	293	67	4.85	2.1	5.0	5082	283	2.4	327	60	4.34	2.3	1.6	15963	889	0.8	R 147R77 RF147R77	4							371	53					3.83	2.5	1.8	14078	784	0.87	91	217	15.60	0.87	2.0	12480	695	0.98	107	184	13.25	0.97	2.3	10900	607	1.12	120	165	11.83	1.05	2.6	9822	547	1.24	140	141	10.11	1.14	2.7	9388	517	0.80	R 137R77 RF137R77	4			150	132			9.47	1.19	2.9	8898					490	0.85											178	111	7.97	1.32	3.1	8226	453	0.91	213	93	6.67	1.46	3.3	7772	428	0.97	250	79	5.67	1.69	3.8	6791	374	1.11	281	70	5.06	1.80	4.5	5756	317	1.31	329	60	4.32	2.0	5.0	5193	286	1.45	351	56	4.05	2.0	5.7	4540	250	1.66	416	47	3.41	2.2	6.5	3977	219	1.89	140	141	10.13	0.81	5.6	4798	253	0.84	R 107R77 RF107R77	4									215	92	6.59	1.09	5.8	4647	245	0.87	254	78	5.60	1.19	6.8	3945	208	1.02	284	70	5.00	1.28	7.8	3433	181	1.18	333	59	4.27	1.38					355	56	4.00	1.44					421	47	3.37	1.58						
377	55	3.77	1.50	444	46	3.20	2.0	491	42	2.89	2.4	559	37	2.54	3.0	592	35	2.40	3.3	696	30	2.04	4.3	763	27	1.86	4.4	882	23	1.61	4.6	1014	20	1.40	4.8	452	46	3.14	1.34	538	38	2.64	1.69	599	34	2.37	1.89	696	30	2.04	2.2	740	28	1.92	2.3	861	24	1.65	2.7	959	21	1.48	3.0	1092	19	1.30	3.1	74	268	19.27	1.03	R 47 RF47	4	3.0kW						88	226			16.22	1.15			1.2	20417			1137	0.83	R 167R97 RF167R97	4			98	203																			14.56	1.23							1.4	18172			1012	0.93	113	174	12.54	1.35	1.6	15658	872	1.08	120	164	11.79	1.40	1.8	13827	770	1.22	140	141	10.15	1.53	2.1	11923	664	1.42	157	126	9.07	1.64	2.8	9158	510	1.85	177	111	8.01	1.73	2.6	9697	540	1.26	R 147R87 RF147R87	4	183	108									7.76	1.42			3.1	8296	462	1.47	204	97	6.96	1.54	3.3	7757	432	1.58	237	83	6.00	1.76	3.8	6698	373	1.82	252	78	5.64	1.86	4.3	5926	330	2.1	293	67	4.85	2.1	5.0	5082	283	2.4	327	60	4.34	2.3	1.6	15963	889	0.8	R 147R77 RF147R77	4	371	53									3.83	2.5			1.8	14078	784	0.87	91	217	15.60	0.87	2.0	12480	695	0.98	107	184	13.25	0.97	2.3	10900	607	1.12	120	165	11.83	1.05	2.6	9822	547	1.24	140	141	10.11	1.14	2.7	9388	517	0.80	R 137R77 RF137R77	4	150	132					9.47	1.19			2.9	8898	490	0.85			178	111	7.97	1.32											3.1	8226	453	0.91	213	93	6.67	1.46	3.3	7772	428	0.97	250	79	5.67	1.69	3.8	6791	374	1.11	281	70	5.06	1.80	4.5	5756	317	1.31	329	60	4.32	2.0	5.0	5193	286	1.45	351	56	4.05	2.0	5.7	4540	250	1.66	416	47	3.41	2.2	6.5	3977	219	1.89	140	141	10.13	0.81	5.6	4798	253	0.84	R 107R77 RF107R77	4	215	92									6.59	1.09	5.8	4647	245	0.87	254	78	5.60	1.19	6.8	3945	208	1.02	284	70	5.00	1.28	7.8	3433	181	1.18	333	59	4.27	1.38					355	56	4.00	1.44					421	47	3.37	1.58										
444	46	3.20	2.0	491	42	2.89	2.4	559	37	2.54	3.0	592	35	2.40	3.3	696	30	2.04	4.3	763	27	1.86	4.4	882	23	1.61	4.6	1014	20	1.40	4.8	452	46	3.14	1.34	538	38	2.64	1.69	599	34	2.37	1.89	696	30	2.04	2.2	740	28	1.92	2.3	861	24	1.65	2.7	959	21	1.48	3.0	1092	19	1.30	3.1	74	268	19.27	1.03	R 47 RF47	4	3.0kW						88	226			16.22	1.15			1.2	20417			1137	0.83			R 167R97 RF167R97	4					98	203																			14.56	1.23			1.4	18172			1012	0.93	113	174	12.54	1.35	1.6	15658	872	1.08	120	164	11.79	1.40	1.8	13827	770	1.22	140	141	10.15	1.53	2.1	11923	664	1.42	157	126	9.07	1.64	2.8	9158	510	1.85	177	111	8.01	1.73	2.6	9697	540	1.26	R 147R87 RF147R87	4	183	108			7.76	1.42									3.1	8296	462	1.47	204	97	6.96	1.54	3.3	7757	432	1.58	237	83	6.00	1.76	3.8	6698	373	1.82	252	78	5.64	1.86	4.3	5926	330	2.1	293	67	4.85	2.1	5.0	5082	283	2.4	327	60	4.34	2.3	1.6	15963	889	0.8	R 147R77 RF147R77	4	371	53			3.83	2.5									1.8	14078	784	0.87	91	217	15.60	0.87	2.0	12480	695	0.98	107	184	13.25	0.97	2.3	10900	607	1.12	120	165	11.83	1.05	2.6	9822	547	1.24	140	141	10.11	1.14	2.7	9388	517	0.80	R 137R77 RF137R77	4	150	132			9.47	1.19					2.9	8898			490	0.85	178	111			7.97	1.32	3.1	8226			453	0.91							213	93	6.67	1.46	3.3	7772	428	0.97	250	79	5.67	1.69	3.8	6791	374	1.11	281	70	5.06	1.80	4.5	5756	317	1.31	329	60	4.32	2.0	5.0	5193	286	1.45	351	56	4.05	2.0	5.7	4540	250	1.66	416	47	3.41	2.2	6.5	3977	219	1.89	140	141	10.13	0.81	5.6	4798	253	0.84	R 107R77 RF107R77	4	215	92			6.59	1.09							5.8	4647	245	0.87	254	78	5.60	1.19	6.8	3945	208	1.02	284	70	5.00	1.28	7.8	3433	181	1.18	333	59	4.27	1.38					355	56	4.00	1.44					421	47	3.37	1.58														
491	42	2.89	2.4	559	37	2.54	3.0	592	35	2.40	3.3	696	30	2.04	4.3	763	27	1.86	4.4	882	23	1.61	4.6	1014	20	1.40	4.8	452	46	3.14	1.34	538	38	2.64	1.69	599	34	2.37	1.89	696	30	2.04	2.2	740	28	1.92	2.3	861	24	1.65	2.7	959	21	1.48	3.0	1092	19	1.30	3.1	74	268	19.27	1.03	R 47 RF47	4	3.0kW								88	226	16.22	1.15			1.2	20417			1137	0.83			R 167R97 RF167R97	4									98	203															14.56	1.23			1.4	18172			1012	0.93	113	174	12.54	1.35	1.6	15658	872	1.08	120	164	11.79	1.40	1.8	13827	770	1.22	140	141	10.15	1.53	2.1	11923	664	1.42	157	126	9.07	1.64	2.8	9158	510	1.85	177	111	8.01	1.73	2.6	9697	540	1.26	R 147R87 RF147R87	4	183	108			7.76	1.42			3.1	8296							462	1.47	204	97	6.96	1.54	3.3	7757	432	1.58	237	83	6.00	1.76	3.8	6698	373	1.82	252	78	5.64	1.86	4.3	5926	330	2.1	293	67	4.85	2.1	5.0	5082	283	2.4	327	60	4.34	2.3	1.6	15963	889	0.8	R 147R77 RF147R77	4	371	53			3.83	2.5			1.8	14078							784	0.87	91	217	15.60	0.87	2.0	12480	695	0.98	107	184	13.25	0.97	2.3	10900	607	1.12	120	165	11.83	1.05	2.6	9822	547	1.24	140	141	10.11	1.14	2.7	9388	517	0.80	R 137R77 RF137R77	4	150	132			9.47	1.19			2.9	8898					490	0.85			178	111	7.97	1.32			3.1	8226	453	0.91			213	93					6.67	1.46	3.3	7772	428	0.97	250	79	5.67	1.69	3.8	6791	374	1.11	281	70	5.06	1.80	4.5	5756	317	1.31	329	60	4.32	2.0	5.0	5193	286	1.45	351	56	4.05	2.0	5.7	4540	250	1.66	416	47	3.41	2.2	6.5	3977	219	1.89	140	141	10.13	0.81	5.6	4798	253	0.84	R 107R77 RF107R77	4	215	92			6.59	1.09			5.8	4647					245	0.87	254	78	5.60	1.19	6.8	3945	208	1.02	284	70	5.00	1.28	7.8	3433	181	1.18	333	59	4.27	1.38					355	56	4.00	1.44					421	47	3.37	1.58																		
559	37	2.54	3.0	592	35	2.40	3.3	696	30	2.04	4.3	763	27	1.86	4.4	882	23	1.61	4.6	1014	20	1.40	4.8	452	46	3.14	1.34	538	38	2.64	1.69	599	34	2.37	1.89	696	30	2.04	2.2	740	28	1.92	2.3	861	24	1.65	2.7	959	21	1.48	3.0	1092	19	1.30	3.1	74	268	19.27	1.03	R 47 RF47	4	3.0kW								88	226			16.22	1.15	1.2	20417			1137	0.83			R 167R97 RF167R97	4													98	203											14.56	1.23			1.4	18172			1012	0.93	113	174	12.54	1.35	1.6	15658	872	1.08	120	164	11.79	1.40	1.8	13827	770	1.22	140	141	10.15	1.53	2.1	11923	664	1.42	157	126	9.07	1.64	2.8	9158	510	1.85	177	111	8.01	1.73	2.6	9697	540	1.26	R 147R87 RF147R87	4	183	108			7.76	1.42			3.1	8296			462	1.47					204	97	6.96	1.54	3.3	7757	432	1.58	237	83	6.00	1.76	3.8	6698	373	1.82	252	78	5.64	1.86	4.3	5926	330	2.1	293	67	4.85	2.1	5.0	5082	283	2.4	327	60	4.34	2.3	1.6	15963	889	0.8	R 147R77 RF147R77	4	371	53			3.83	2.5			1.8	14078			784	0.87					91	217	15.60	0.87	2.0	12480	695	0.98	107	184	13.25	0.97	2.3	10900	607	1.12	120	165	11.83	1.05	2.6	9822	547	1.24	140	141	10.11	1.14	2.7	9388	517	0.80	R 137R77 RF137R77	4	150	132			9.47	1.19			2.9	8898			490	0.85					178	111			7.97	1.32	3.1	8226			453	0.91	213	93			6.67	1.46			3.3	7772	428	0.97	250	79	5.67	1.69	3.8	6791	374	1.11	281	70	5.06	1.80	4.5	5756	317	1.31	329	60	4.32	2.0	5.0	5193	286	1.45	351	56	4.05	2.0	5.7	4540	250	1.66	416	47	3.41	2.2	6.5	3977	219	1.89	140	141	10.13	0.81	5.6	4798	253	0.84	R 107R77 RF107R77	4	215	92			6.59	1.09			5.8	4647			245	0.87			254	78	5.60	1.19	6.8	3945	208	1.02	284	70	5.00	1.28	7.8	3433	181	1.18	333	59	4.27	1.38					355	56	4.00	1.44					421	47	3.37	1.58																						
592	35	2.40	3.3	696	30	2.04	4.3	763	27	1.86	4.4	882	23	1.61	4.6	1014	20	1.40	4.8	452	46	3.14	1.34	538	38	2.64	1.69	599	34	2.37	1.89	696	30	2.04	2.2	740	28	1.92	2.3	861	24	1.65	2.7	959	21	1.48	3.0	1092	19	1.30	3.1	74	268	19.27	1.03	R 47 RF47	4	3.0kW								88	226			16.22	1.15			1.2	20417	1137	0.83			R 167R97 RF167R97	4																	98	203							14.56	1.23			1.4	18172			1012	0.93	113	174	12.54	1.35	1.6	15658	872	1.08	120	164	11.79	1.40	1.8	13827	770	1.22	140	141	10.15	1.53	2.1	11923	664	1.42	157	126	9.07	1.64	2.8	9158	510	1.85	177	111	8.01	1.73	2.6	9697	540	1.26	R 147R87 RF147R87	4	183	108			7.76	1.42			3.1	8296			462	1.47			204	97			6.96	1.54	3.3	7757	432	1.58	237	83	6.00	1.76	3.8	6698	373	1.82	252	78	5.64	1.86	4.3	5926	330	2.1	293	67	4.85	2.1	5.0	5082	283	2.4	327	60	4.34	2.3	1.6	15963	889	0.8	R 147R77 RF147R77	4	371	53			3.83	2.5			1.8	14078			784	0.87			91	217			15.60	0.87	2.0	12480	695	0.98	107	184	13.25	0.97	2.3	10900	607	1.12	120	165	11.83	1.05	2.6	9822	547	1.24	140	141	10.11	1.14	2.7	9388	517	0.80	R 137R77 RF137R77	4	150	132			9.47	1.19			2.9	8898			490	0.85			178	111					7.97	1.32			3.1	8226	453	0.91			213	93	6.67	1.46			3.3	7772	428	0.97	250	79	5.67	1.69	3.8	6791	374	1.11	281	70	5.06	1.80	4.5	5756	317	1.31	329	60	4.32	2.0	5.0	5193	286	1.45	351	56	4.05	2.0	5.7	4540	250	1.66	416	47	3.41	2.2	6.5	3977	219	1.89	140	141	10.13	0.81	5.6	4798	253	0.84	R 107R77 RF107R77	4	215	92			6.59	1.09			5.8	4647			245	0.87			254	78	5.60	1.19	6.8	3945	208	1.02	284	70	5.00	1.28	7.8	3433	181	1.18	333	59	4.27	1.38					355	56	4.00	1.44					421	47	3.37	1.58																										
696	30	2.04	4.3	763	27	1.86	4.4	882	23	1.61	4.6	1014	20	1.40	4.8	452	46	3.14	1.34	538	38	2.64	1.69	599	34	2.37	1.89	696	30	2.04	2.2	740	28	1.92	2.3	861	24	1.65	2.7	959	21	1.48	3.0	1092	19	1.30	3.1	74	268	19.27	1.03	R 47 RF47	4	3.0kW								88	226			16.22	1.15			1.2	20417			1137	0.83	R 167R97 RF167R97	4																					98	203			14.56	1.23			1.4	18172			1012	0.93	113	174	12.54	1.35	1.6	15658	872	1.08	120	164	11.79	1.40	1.8	13827	770	1.22	140	141	10.15	1.53	2.1	11923	664	1.42	157	126	9.07	1.64	2.8	9158	510	1.85	177	111	8.01	1.73	2.6	9697	540	1.26	R 147R87 RF147R87	4	183	108			7.76	1.42			3.1	8296			462	1.47			204	97			6.96	1.54	3.3	7757	432	1.58	237	83	6.00	1.76	3.8	6698	373	1.82	252	78	5.64	1.86	4.3	5926	330	2.1	293	67	4.85	2.1	5.0	5082	283	2.4	327	60	4.34	2.3	1.6	15963	889	0.8	R 147R77 RF147R77	4	371	53			3.83	2.5			1.8	14078			784	0.87			91	217			15.60	0.87	2.0	12480	695	0.98	107	184	13.25	0.97	2.3	10900	607	1.12	120	165	11.83	1.05	2.6	9822	547	1.24	140	141	10.11	1.14	2.7	9388	517	0.80	R 137R77 RF137R77	4	150	132			9.47	1.19			2.9	8898			490	0.85			178	111			7.97	1.32					3.1	8226			453	0.91	213	93			6.67	1.46	3.3	7772	428	0.97	250	79	5.67	1.69	3.8	6791	374	1.11	281	70	5.06	1.80	4.5	5756	317	1.31	329	60	4.32	2.0	5.0	5193	286	1.45	351	56	4.05	2.0	5.7	4540	250	1.66	416	47	3.41	2.2	6.5	3977	219	1.89	140	141	10.13	0.81	5.6	4798	253	0.84	R 107R77 RF107R77	4	215	92			6.59	1.09			5.8	4647			245	0.87			254	78	5.60	1.19	6.8	3945	208	1.02	284	70	5.00	1.28	7.8	3433	181	1.18	333	59	4.27	1.38					355	56	4.00	1.44					421	47	3.37	1.58																														
763	27	1.86	4.4	882	23	1.61	4.6	1014	20	1.40	4.8	452	46	3.14	1.34	538	38	2.64	1.69	599	34	2.37	1.89	696	30	2.04	2.2	740	28	1.92	2.3	861	24	1.65	2.7	959	21	1.48	3.0	1092	19	1.30	3.1	74	268	19.27	1.03	R 47 RF47	4	3.0kW								88	226			16.22	1.15			1.2	20417			1137	0.83			R 167R97 RF167R97	4																			98	203			14.56	1.23			1.4	18172			1012	0.93	113	174	12.54	1.35	1.6	15658	872	1.08	120	164	11.79	1.40	1.8	13827	770	1.22	140	141	10.15	1.53	2.1	11923	664	1.42	157	126	9.07	1.64	2.8	9158	510	1.85	177	111	8.01	1.73	2.6	9697	540	1.26	R 147R87 RF147R87	4	183	108			7.76	1.42			3.1	8296			462	1.47			204	97			6.96	1.54	3.3	7757	432	1.58	237	83	6.00	1.76	3.8	6698	373	1.82	252	78	5.64	1.86	4.3	5926	330	2.1	293	67	4.85	2.1	5.0	5082	283	2.4	327	60	4.34	2.3	1.6	15963	889	0.8	R 147R77 RF147R77	4	371	53			3.83	2.5			1.8	14078			784	0.87			91	217			15.60	0.87	2.0	12480	695	0.98	107	184	13.25	0.97	2.3	10900	607	1.12	120	165	11.83	1.05	2.6	9822	547	1.24	140	141	10.11	1.14	2.7	9388	517	0.80	R 137R77 RF137R77	4	150	132			9.47	1.19			2.9	8898			490	0.85			178	111			7.97	1.32			3.1	8226					453	0.91			213	93	6.67	1.46	3.3	7772	428	0.97	250	79	5.67	1.69	3.8	6791	374	1.11	281	70	5.06	1.80	4.5	5756	317	1.31	329	60	4.32	2.0	5.0	5193	286	1.45	351	56	4.05	2.0	5.7	4540	250	1.66	416	47	3.41	2.2	6.5	3977	219	1.89	140	141	10.13	0.81	5.6	4798	253	0.84	R 107R77 RF107R77	4	215	92			6.59	1.09			5.8	4647			245	0.87			254	78	5.60	1.19	6.8	3945	208	1.02	284	70	5.00	1.28	7.8	3433	181	1.18	333	59	4.27	1.38					355	56	4.00	1.44					421	47	3.37	1.58																																		
882	23	1.61	4.6	1014	20	1.40	4.8	452	46	3.14	1.34	538	38	2.64	1.69	599	34	2.37	1.89	696	30	2.04	2.2	740	28	1.92	2.3	861	24	1.65	2.7	959	21	1.48	3.0	1092	19	1.30	3.1	74	268	19.27	1.03	R 47 RF47	4	3.0kW								88	226			16.22	1.15			1.2	20417			1137	0.83			R 167R97 RF167R97	4																					98	203	14.56	1.23			1.4	18172			1012	0.93	113	174	12.54	1.35	1.6	15658	872	1.08	120	164	11.79	1.40	1.8	13827	770	1.22	140	141	10.15	1.53	2.1	11923	664	1.42	157	126	9.07	1.64	2.8	9158	510	1.85	177	111	8.01	1.73	2.6	9697	540	1.26	R 147R87 RF147R87	4	183	108			7.76	1.42			3.1	8296			462	1.47			204	97			6.96	1.54	3.3	7757	432	1.58	237	83	6.00	1.76	3.8	6698	373	1.82	252	78	5.64	1.86	4.3	5926	330	2.1	293	67	4.85	2.1	5.0	5082	283	2.4	327	60	4.34	2.3	1.6	15963	889	0.8	R 147R77 RF147R77	4	371	53			3.83	2.5			1.8	14078			784	0.87			91	217			15.60	0.87	2.0	12480	695	0.98	107	184	13.25	0.97	2.3	10900	607	1.12	120	165	11.83	1.05	2.6	9822	547	1.24	140	141	10.11	1.14	2.7	9388	517	0.80	R 137R77 RF137R77	4	150	132			9.47	1.19			2.9	8898			490	0.85			178	111			7.97	1.32			3.1	8226			453	0.91					213	93	6.67	1.46	3.3	7772	428	0.97	250	79	5.67	1.69	3.8	6791	374	1.11	281	70	5.06	1.80	4.5	5756	317	1.31	329	60	4.32	2.0	5.0	5193	286	1.45	351	56	4.05	2.0	5.7	4540	250	1.66	416	47	3.41	2.2	6.5	3977	219	1.89	140	141	10.13	0.81	5.6	4798	253	0.84	R 107R77 RF107R77	4	215	92			6.59	1.09			5.8	4647			245	0.87			254	78	5.60	1.19	6.8	3945	208	1.02	284	70	5.00	1.28	7.8	3433	181	1.18	333	59	4.27	1.38					355	56	4.00	1.44					421	47	3.37	1.58																																						
1014	20	1.40	4.8	452	46	3.14	1.34	538	38	2.64	1.69	599	34	2.37	1.89	696	30	2.04	2.2	740	28	1.92	2.3	861	24	1.65	2.7	959	21	1.48	3.0	1092	19	1.30	3.1	74	268	19.27	1.03	R 47 RF47	4	3.0kW								88	226			16.22	1.15			1.2	20417			1137	0.83			R 167R97 RF167R97	4																					98	203			14.56	1.23	1.4	18172			1012	0.93	113	174	12.54	1.35	1.6	15658	872	1.08	120	164	11.79	1.40	1.8	13827	770	1.22	140	141	10.15	1.53	2.1	11923	664	1.42	157	126	9.07	1.64	2.8	9158	510	1.85	177	111	8.01	1.73	2.6	9697	540	1.26	R 147R87 RF147R87	4	183	108			7.76	1.42			3.1	8296			462	1.47			204	97			6.96	1.54	3.3	7757	432	1.58	237	83	6.00	1.76	3.8	6698	373	1.82	252	78	5.64	1.86	4.3	5926	330	2.1	293	67	4.85	2.1	5.0	5082	283	2.4	327	60	4.34	2.3	1.6	15963	889	0.8	R 147R77 RF147R77	4	371	53			3.83	2.5			1.8	14078			784	0.87			91	217			15.60	0.87	2.0	12480	695	0.98	107	184	13.25	0.97	2.3	10900	607	1.12	120	165	11.83	1.05	2.6	9822	547	1.24	140	141	10.11	1.14	2.7	9388	517	0.80	R 137R77 RF137R77	4	150	132			9.47	1.19			2.9	8898			490	0.85			178	111			7.97	1.32			3.1	8226			453	0.91			213	93			6.67	1.46	3.3	7772	428	0.97	250	79	5.67	1.69	3.8	6791	374	1.11	281	70	5.06	1.80	4.5	5756	317	1.31	329	60	4.32	2.0	5.0	5193	286	1.45	351	56	4.05	2.0	5.7	4540	250	1.66	416	47	3.41	2.2	6.5	3977	219	1.89	140	141	10.13	0.81	5.6	4798	253	0.84	R 107R77 RF107R77	4	215	92			6.59	1.09			5.8	4647			245	0.87			254	78	5.60	1.19	6.8	3945	208	1.02	284	70	5.00	1.28	7.8	3433	181	1.18	333	59	4.27	1.38					355	56	4.00	1.44					421	47	3.37	1.58																																										
452	46	3.14	1.34	538	38	2.64	1.69	599	34	2.37	1.89	696	30	2.04	2.2	740	28	1.92	2.3	861	24	1.65	2.7	959	21	1.48	3.0	1092	19	1.30	3.1	74	268	19.27	1.03	R 47 RF47	4	3.0kW								88	226			16.22	1.15			1.2	20417			1137	0.83			R 167R97 RF167R97	4																					98	203			14.56	1.23			1.4	18172	1012	0.93	113	174	12.54	1.35	1.6	15658	872	1.08	120	164	11.79	1.40	1.8	13827	770	1.22	140	141	10.15	1.53	2.1	11923	664	1.42	157	126	9.07	1.64	2.8	9158	510	1.85	177	111	8.01	1.73	2.6	9697	540	1.26	R 147R87 RF147R87	4	183	108			7.76	1.42			3.1	8296			462	1.47			204	97			6.96	1.54	3.3	7757	432	1.58	237	83	6.00	1.76	3.8	6698	373	1.82	252	78	5.64	1.86	4.3	5926	330	2.1	293	67	4.85	2.1	5.0	5082	283	2.4	327	60	4.34	2.3	1.6	15963	889	0.8	R 147R77 RF147R77	4	371	53			3.83	2.5			1.8	14078			784	0.87			91	217			15.60	0.87	2.0	12480	695	0.98	107	184	13.25	0.97	2.3	10900	607	1.12	120	165	11.83	1.05	2.6	9822	547	1.24	140	141	10.11	1.14	2.7	9388	517	0.80	R 137R77 RF137R77	4	150	132			9.47	1.19			2.9	8898			490	0.85			178	111			7.97	1.32			3.1	8226			453	0.91			213	93			6.67	1.46	3.3	7772	428	0.97	250	79	5.67	1.69	3.8	6791	374	1.11	281	70	5.06	1.80	4.5	5756	317	1.31	329	60	4.32	2.0	5.0	5193	286	1.45	351	56	4.05	2.0	5.7	4540	250	1.66	416	47	3.41	2.2	6.5	3977	219	1.89	140	141	10.13	0.81	5.6	4798	253	0.84	R 107R77 RF107R77	4	215	92			6.59	1.09			5.8	4647			245	0.87			254	78	5.60	1.19	6.8	3945	208	1.02	284	70	5.00	1.28	7.8	3433	181	1.18	333	59	4.27	1.38					355	56	4.00	1.44					421	47	3.37	1.58																																														
538	38	2.64	1.69	599	34	2.37	1.89	696	30	2.04	2.2	740	28	1.92	2.3	861	24	1.65	2.7	959	21	1.48	3.0	1092	19	1.30	3.1	74	268	19.27	1.03	R 47 RF47	4	3.0kW								88	226			16.22	1.15			1.2	20417			1137	0.83			R 167R97 RF167R97	4																					98	203			14.56	1.23			1.4	18172	1012	0.93	113	174	12.54	1.35	1.6	15658	872	1.08	120	164	11.79	1.40	1.8	13827	770	1.22	140	141	10.15	1.53	2.1	11923	664	1.42	157	126	9.07	1.64	2.8	9158	510	1.85	177	111	8.01	1.73	2.6	9697	540	1.26	R 147R87 RF147R87	4	183	108			7.76	1.42			3.1	8296			462	1.47			204	97			6.96	1.54	3.3	7757	432	1.58	237	83	6.00	1.76	3.8	6698	373	1.82	252	78	5.64	1.86	4.3	5926	330	2.1	293	67	4.85	2.1	5.0	5082	283	2.4	327	60	4.34	2.3	1.6	15963	889	0.8	R 147R77 RF147R77	4	371	53			3.83	2.5			1.8	14078			784	0.87			91	217			15.60	0.87	2.0	12480	695	0.98	107	184	13.25	0.97	2.3	10900	607	1.12	120	165	11.83	1.05	2.6	9822	547	1.24	140	141	10.11	1.14	2.7	9388	517	0.80	R 137R77 RF137R77	4	150	132			9.47	1.19			2.9	8898			490	0.85			178	111			7.97	1.32			3.1	8226			453	0.91			213	93			6.67	1.46	3.3	7772	428	0.97	250	79	5.67	1.69	3.8	6791	374	1.11	281	70	5.06	1.80	4.5	5756	317	1.31	329	60	4.32	2.0	5.0	5193	286	1.45	351	56	4.05	2.0	5.7	4540	250	1.66	416	47	3.41	2.2	6.5	3977	219	1.89	140	141	10.13	0.81	5.6	4798	253	0.84	R 107R77 RF107R77	4	215	92			6.59	1.09			5.8	4647			245	0.87			254	78	5.60	1.19	6.8	3945	208	1.02	284	70	5.00	1.28	7.8	3433	181	1.18	333	59	4.27	1.38					355	56	4.00	1.44					421	47	3.37	1.58																																																		
599	34	2.37	1.89	696	30	2.04	2.2	740	28	1.92	2.3	861	24	1.65	2.7	959	21	1.48	3.0	1092	19	1.30	3.1	74	268	19.27	1.03	R 47 RF47	4	3.0kW								88	226			16.22	1.15			1.2	20417			1137	0.83			R 167R97 RF167R97	4																					98	203			14.56	1.23			1.4	18172	1012	0.93	113	174	12.54	1.35	1.6	15658	872	1.08	120	164	11.79	1.40	1.8	13827	770	1.22	140	141	10.15	1.53	2.1	11923	664	1.42	157	126	9.07	1.64	2.8	9158	510	1.85	177	111	8.01	1.73	2.6	9697	540	1.26	R 147R87 RF147R87	4	183	108			7.76	1.42			3.1	8296			462	1.47			204	97			6.96	1.54	3.3	7757	432	1.58	237	83	6.00	1.76	3.8	6698	373	1.82	252	78	5.64	1.86	4.3	5926	330	2.1	293	67	4.85	2.1	5.0	5082	283	2.4	327	60	4.34	2.3	1.6	15963	889	0.8	R 147R77 RF147R77	4	371	53			3.83	2.5			1.8	14078			784	0.87			91	217			15.60	0.87	2.0	12480	695	0.98	107	184	13.25	0.97	2.3	10900	607	1.12	120	165	11.83	1.05	2.6	9822	547	1.24	140	141	10.11	1.14	2.7	9388	517	0.80	R 137R77 RF137R77	4	150	132			9.47	1.19			2.9	8898			490	0.85			178	111			7.97	1.32			3.1	8226			453	0.91			213	93			6.67	1.46	3.3	7772	428	0.97	250	79	5.67	1.69	3.8	6791	374	1.11	281	70	5.06	1.80	4.5	5756	317	1.31	329	60	4.32	2.0	5.0	5193	286	1.45	351	56	4.05	2.0	5.7	4540	250	1.66	416	47	3.41	2.2	6.5	3977	219	1.89	140	141	10.13	0.81	5.6	4798	253	0.84	R 107R77 RF107R77	4	215	92			6.59	1.09			5.8	4647			245	0.87			254	78	5.60	1.19	6.8	3945	208	1.02	284	70	5.00	1.28	7.8	3433	181	1.18	333	59	4.27	1.38					355	56	4.00	1.44					421	47	3.37	1.58																																																						
696	30	2.04	2.2	740	28	1.92	2.3	861	24	1.65	2.7	959	21	1.48	3.0	1092	19	1.30	3.1	74	268	19.27	1.03	R 47 RF47	4	3.0kW								88	226			16.22	1.15			1.2	20417			1137	0.83			R 167R97 RF167R97	4																							98	203	14.56	1.23			1.4	18172	1012	0.93	113	174	12.54	1.35	1.6	15658	872	1.08	120	164	11.79	1.40	1.8	13827	770	1.22	140	141	10.15	1.53	2.1	11923	664	1.42	157	126	9.07	1.64	2.8	9158	510	1.85	177	111	8.01	1.73	2.6	9697	540	1.26	R 147R87 RF147R87	4	183	108			7.76	1.42			3.1	8296			462	1.47			204	97			6.96	1.54	3.3	7757	432	1.58	237	83	6.00	1.76	3.8	6698	373	1.82	252	78	5.64	1.86	4.3	5926	330	2.1	293	67	4.85	2.1	5.0	5082	283	2.4	327	60	4.34	2.3	1.6	15963	889	0.8	R 147R77 RF147R77	4	371	53			3.83	2.5			1.8	14078			784	0.87			91	217			15.60	0.87	2.0	12480	695	0.98	107	184	13.25	0.97	2.3	10900	607	1.12	120	165	11.83	1.05	2.6	9822	547	1.24	140	141	10.11	1.14	2.7	9388	517	0.80	R 137R77 RF137R77	4	150	132			9.47	1.19			2.9	8898			490	0.85			178	111			7.97	1.32			3.1	8226			453	0.91			213	93			6.67	1.46	3.3	7772	428	0.97	250	79	5.67	1.69	3.8	6791	374	1.11	281	70	5.06	1.80	4.5	5756	317	1.31	329	60	4.32	2.0	5.0	5193	286	1.45	351	56	4.05	2.0	5.7	4540	250	1.66	416	47	3.41	2.2	6.5	3977	219	1.89	140	141	10.13	0.81	5.6	4798	253	0.84	R 107R77 RF107R77	4	215	92			6.59	1.09			5.8	4647			245	0.87			254	78	5.60	1.19	6.8	3945	208	1.02	284	70	5.00	1.28	7.8	3433	181	1.18	333	59	4.27	1.38					355	56	4.00	1.44					421	47	3.37	1.58																																																										
740	28	1.92	2.3	861	24	1.65	2.7	959	21	1.48	3.0	1092	19	1.30	3.1	74	268	19.27	1.03	R 47 RF47	4	3.0kW								88	226			16.22	1.15			1.2	20417			1137	0.83			R 167R97 RF167R97	4																							98	203			14.56	1.23	1.4	18172	1012	0.93	113	174	12.54	1.35	1.6	15658	872	1.08	120	164	11.79	1.40	1.8	13827	770	1.22	140	141	10.15	1.53	2.1	11923	664	1.42	157	126	9.07	1.64	2.8	9158	510	1.85	177	111	8.01	1.73	2.6	9697	540	1.26	R 147R87 RF147R87	4	183	108			7.76	1.42			3.1	8296			462	1.47			204	97			6.96	1.54	3.3	7757	432	1.58	237	83	6.00	1.76	3.8	6698	373	1.82	252	78	5.64	1.86	4.3	5926	330	2.1	293	67	4.85	2.1	5.0	5082	283	2.4	327	60	4.34	2.3	1.6	15963	889	0.8	R 147R77 RF147R77	4	371	53			3.83	2.5			1.8	14078			784	0.87			91	217			15.60	0.87	2.0	12480	695	0.98	107	184	13.25	0.97	2.3	10900	607	1.12	120	165	11.83	1.05	2.6	9822	547	1.24	140	141	10.11	1.14	2.7	9388	517	0.80	R 137R77 RF137R77	4	150	132			9.47	1.19			2.9	8898			490	0.85			178	111			7.97	1.32			3.1	8226			453	0.91			213	93			6.67	1.46	3.3	7772	428	0.97	250	79	5.67	1.69	3.8	6791	374	1.11	281	70	5.06	1.80	4.5	5756	317	1.31	329	60	4.32	2.0	5.0	5193	286	1.45	351	56	4.05	2.0	5.7	4540	250	1.66	416	47	3.41	2.2	6.5	3977	219	1.89	140	141	10.13	0.81	5.6	4798	253	0.84	R 107R77 RF107R77	4	215	92			6.59	1.09			5.8	4647			245	0.87			254	78	5.60	1.19	6.8	3945	208	1.02	284	70	5.00	1.28	7.8	3433	181	1.18	333	59	4.27	1.38					355	56	4.00	1.44					421	47	3.37	1.58																																																														
861	24	1.65	2.7	959	21	1.48	3.0	1092	19	1.30	3.1	74	268	19.27	1.03	R 47 RF47	4	3.0kW								88	226			16.22	1.15			1.2	20417			1137	0.83			R 167R97 RF167R97	4																							98	203			14.56	1.23	1.4	18172	1012	0.93	113	174	12.54	1.35	1.6	15658	872	1.08	120	164	11.79	1.40	1.8	13827	770	1.22	140	141	10.15	1.53	2.1	11923	664	1.42	157	126	9.07	1.64	2.8	9158	510	1.85	177	111	8.01	1.73	2.6	9697	540	1.26	R 147R87 RF147R87	4	183	108			7.76	1.42			3.1	8296			462	1.47			204	97			6.96	1.54	3.3	7757	432	1.58	237	83	6.00	1.76	3.8	6698	373	1.82	252	78	5.64	1.86	4.3	5926	330	2.1	293	67	4.85	2.1	5.0	5082	283	2.4	327	60	4.34	2.3	1.6	15963	889	0.8	R 147R77 RF147R77	4	371	53			3.83	2.5			1.8	14078			784	0.87			91	217			15.60	0.87	2.0	12480	695	0.98	107	184	13.25	0.97	2.3	10900	607	1.12	120	165	11.83	1.05	2.6	9822	547	1.24	140	141	10.11	1.14	2.7	9388	517	0.80	R 137R77 RF137R77	4	150	132			9.47	1.19			2.9	8898			490	0.85			178	111			7.97	1.32			3.1	8226			453	0.91			213	93			6.67	1.46	3.3	7772	428	0.97	250	79	5.67	1.69	3.8	6791	374	1.11	281	70	5.06	1.80	4.5	5756	317	1.31	329	60	4.32	2.0	5.0	5193	286	1.45	351	56	4.05	2.0	5.7	4540	250	1.66	416	47	3.41	2.2	6.5	3977	219	1.89	140	141	10.13	0.81	5.6	4798	253	0.84	R 107R77 RF107R77	4	215	92			6.59	1.09			5.8	4647			245	0.87			254	78	5.60	1.19	6.8	3945	208	1.02	284	70	5.00	1.28	7.8	3433	181	1.18	333	59	4.27	1.38					355	56	4.00	1.44					421	47	3.37	1.58																																																																		
959	21	1.48	3.0	1092	19	1.30	3.1	74	268	19.27	1.03	R 47 RF47	4	3.0kW								88	226			16.22	1.15			1.2	20417			1137	0.83			R 167R97 RF167R97	4																							98	203			14.56	1.23	1.4	18172	1012	0.93	113	174	12.54	1.35	1.6	15658	872	1.08	120	164	11.79	1.40	1.8	13827	770	1.22	140	141	10.15	1.53	2.1	11923	664	1.42	157	126	9.07	1.64	2.8	9158	510	1.85	177	111	8.01	1.73	2.6	9697	540	1.26	R 147R87 RF147R87	4	183	108			7.76	1.42			3.1	8296			462	1.47			204	97			6.96	1.54	3.3	7757	432	1.58	237	83	6.00	1.76	3.8	6698	373	1.82	252	78	5.64	1.86	4.3	5926	330	2.1	293	67	4.85	2.1	5.0	5082	283	2.4	327	60	4.34	2.3	1.6	15963	889	0.8	R 147R77 RF147R77	4	371	53			3.83	2.5			1.8	14078			784	0.87			91	217			15.60	0.87	2.0	12480	695	0.98	107	184	13.25	0.97	2.3	10900	607	1.12	120	165	11.83	1.05	2.6	9822	547	1.24	140	141	10.11	1.14	2.7	9388	517	0.80	R 137R77 RF137R77	4	150	132			9.47	1.19			2.9	8898			490	0.85			178	111			7.97	1.32			3.1	8226			453	0.91			213	93			6.67	1.46	3.3	7772	428	0.97	250	79	5.67	1.69	3.8	6791	374	1.11	281	70	5.06	1.80	4.5	5756	317	1.31	329	60	4.32	2.0	5.0	5193	286	1.45	351	56	4.05	2.0	5.7	4540	250	1.66	416	47	3.41	2.2	6.5	3977	219	1.89	140	141	10.13	0.81	5.6	4798	253	0.84	R 107R77 RF107R77	4	215	92			6.59	1.09			5.8	4647			245	0.87			254	78	5.60	1.19	6.8	3945	208	1.02	284	70	5.00	1.28	7.8	3433	181	1.18	333	59	4.27	1.38					355	56	4.00	1.44					421	47	3.37	1.58																																																																						
1092	19	1.30	3.1	74	268	19.27	1.03	R 47 RF47	4	3.0kW								88	226			16.22	1.15			1.2	20417			1137	0.83			R 167R97 RF167R97	4																							98	203			14.56	1.23	1.4	18172	1012	0.93	113	174	12.54	1.35	1.6	15658	872	1.08	120	164	11.79	1.40	1.8	13827	770	1.22	140	141	10.15	1.53	2.1	11923	664	1.42	157	126	9.07	1.64	2.8	9158	510	1.85	177	111	8.01	1.73	2.6	9697	540	1.26	R 147R87 RF147R87	4	183	108			7.76	1.42			3.1	8296			462	1.47			204	97			6.96	1.54	3.3	7757	432	1.58	237	83	6.00	1.76	3.8	6698	373	1.82	252	78	5.64	1.86	4.3	5926	330	2.1	293	67	4.85	2.1	5.0	5082	283	2.4	327	60	4.34	2.3	1.6	15963	889	0.8	R 147R77 RF147R77	4	371	53			3.83	2.5			1.8	14078			784	0.87			91	217			15.60	0.87	2.0	12480	695	0.98	107	184	13.25	0.97	2.3	10900	607	1.12	120	165	11.83	1.05	2.6	9822	547	1.24	140	141	10.11	1.14	2.7	9388	517	0.80	R 137R77 RF137R77	4	150	132			9.47	1.19			2.9	8898			490	0.85			178	111			7.97	1.32			3.1	8226			453	0.91			213	93			6.67	1.46	3.3	7772	428	0.97	250	79	5.67	1.69	3.8	6791	374	1.11	281	70	5.06	1.80	4.5	5756	317	1.31	329	60	4.32	2.0	5.0	5193	286	1.45	351	56	4.05	2.0	5.7	4540	250	1.66	416	47	3.41	2.2	6.5	3977	219	1.89	140	141	10.13	0.81	5.6	4798	253	0.84	R 107R77 RF107R77	4	215	92			6.59	1.09			5.8	4647			245	0.87			254	78	5.60	1.19	6.8	3945	208	1.02	284	70	5.00	1.28	7.8	3433	181	1.18	333	59	4.27	1.38					355	56	4.00	1.44					421	47	3.37	1.58																																																																										
74	268	19.27	1.03	R 47 RF47	4	3.0kW																																																																																																																																																																																																																																																																																																																																																																																																																																																	
88	226	16.22	1.15			1.2	20417			1137	0.83			R 167R97 RF167R97	4																																																																																																																																																																																																																																																																																																																																																																																																																																								
98	203	14.56	1.23			1.4	18172			1012	0.93																																																																																																																																																																																																																																																																																																																																																																																																																																												
113	174	12.54	1.35			1.6	15658			872	1.08																																																																																																																																																																																																																																																																																																																																																																																																																																												
120	164	11.79	1.40			1.8	13827			770	1.22																																																																																																																																																																																																																																																																																																																																																																																																																																												
140	141	10.15	1.53			2.1	11923			664	1.42																																																																																																																																																																																																																																																																																																																																																																																																																																												
157	126	9.07	1.64			2.8	9158			510	1.85							177	111			8.01	1.73			2.6	9697			540	1.26			R 147R87 RF147R87	4	183	108	7.76	1.42	3.1	8296	462	1.47	204	97	6.96	1.54	3.3	7757	432	1.58	237	83	6.00	1.76	3.8	6698	373	1.82	252	78	5.64	1.86	4.3	5926	330	2.1	293	67	4.85	2.1	5.0	5082	283	2.4	327	60	4.34	2.3	1.6	15963	889	0.8	R 147R77 RF147R77	4	371	53	3.83	2.5	1.8	14078	784	0.87	91	217	15.60	0.87	2.0	12480	695	0.98	107	184	13.25	0.97	2.3	10900	607	1.12	120	165	11.83	1.05	2.6	9822	547	1.24	140	141	10.11	1.14	2.7	9388	517	0.80	R 137R77 RF137R77	4	150	132	9.47	1.19	2.9	8898	490	0.85	178	111	7.97	1.32	3.1	8226	453	0.91	213	93	6.67	1.46	3.3	7772	428	0.97	250	79	5.67	1.69	3.8	6791	374	1.11	281	70	5.06	1.80	4.5	5756	317	1.31	329	60	4.32	2.0	5.0	5193	286	1.45	351	56	4.05	2.0	5.7	4540	250	1.66	416	47	3.41	2.2	6.5	3977	219	1.89	140	141	10.13	0.81	5.6	4798	253	0.84	R 107R77 RF107R77	4	215	92	6.59	1.09	5.8	4647	245	0.87	254	78	5.60	1.19	6.8	3945	208	1.02	284	70			5.00	1.28			7.8	3433			181	1.18	333	59	4.27	1.38					355	56	4.00	1.44					421	47	3.37	1.58																																																																																																																																																																																												
177	111	8.01	1.73			2.6	9697			540	1.26			R 147R87 RF147R87	4																																																																																																																																																																																																																																																																																																																																																																																																																																								
183	108	7.76	1.42			3.1	8296			462	1.47																																																																																																																																																																																																																																																																																																																																																																																																																																												
204	97	6.96	1.54			3.3	7757			432	1.58																																																																																																																																																																																																																																																																																																																																																																																																																																												
237	83	6.00	1.76			3.8	6698			373	1.82																																																																																																																																																																																																																																																																																																																																																																																																																																												
252	78	5.64	1.86			4.3	5926			330	2.1																																																																																																																																																																																																																																																																																																																																																																																																																																												
293	67	4.85	2.1			5.0	5082			283	2.4	327	60			4.34	2.3	1.6	15963	889	0.8	R 147R77 RF147R77	4	371	53	3.83	2.5	1.8	14078	784	0.87	91	217	15.60	0.87	2.0	12480	695	0.98	107	184	13.25	0.97	2.3	10900	607	1.12	120	165	11.83	1.05	2.6	9822	547	1.24	140	141	10.11	1.14	2.7	9388	517	0.80	R 137R77 RF137R77	4	150	132	9.47	1.19	2.9	8898	490	0.85	178	111	7.97	1.32	3.1	8226	453	0.91	213	93	6.67	1.46	3.3	7772	428	0.97	250	79	5.67	1.69	3.8	6791	374	1.11	281	70	5.06	1.80	4.5	5756	317	1.31	329	60	4.32	2.0	5.0	5193	286	1.45	351	56	4.05	2.0	5.7	4540	250	1.66	416	47	3.41	2.2			6.5	3977	219	1.89	140	141	10.13	0.81	5.6	4798	253	0.84	R 107R77 RF107R77	4	215	92	6.59	1.09	5.8	4647	245	0.87	254	78	5.60	1.19	6.8	3945	208	1.02	284	70	5.00	1.28	7.8	3433	181	1.18	333	59	4.27	1.38					355	56	4.00	1.44					421	47	3.37	1.58																																																																																																																																																																																																																																																														
327	60	4.34	2.3			1.6	15963	889	0.8	R 147R77 RF147R77	4																																																																																																																																																																																																																																																																																																																																																																																																																																												
371	53	3.83	2.5	1.8	14078	784	0.87																																																																																																																																																																																																																																																																																																																																																																																																																																																
91	217	15.60	0.87	2.0	12480	695	0.98																																																																																																																																																																																																																																																																																																																																																																																																																																																
107	184	13.25	0.97	2.3	10900	607	1.12																																																																																																																																																																																																																																																																																																																																																																																																																																																
120	165	11.83	1.05	2.6	9822	547	1.24																																																																																																																																																																																																																																																																																																																																																																																																																																																
140	141	10.11	1.14	2.7	9388	517	0.80	R 137R77 RF137R77	4																																																																																																																																																																																																																																																																																																																																																																																																																																														
150	132	9.47	1.19	2.9	8898	490	0.85																																																																																																																																																																																																																																																																																																																																																																																																																																																
178	111	7.97	1.32	3.1	8226	453	0.91																																																																																																																																																																																																																																																																																																																																																																																																																																																
213	93	6.67	1.46	3.3	7772	428	0.97																																																																																																																																																																																																																																																																																																																																																																																																																																																
250	79	5.67	1.69	3.8	6791	374	1.11																																																																																																																																																																																																																																																																																																																																																																																																																																																
281	70	5.06	1.80	4.5	5756	317	1.31																																																																																																																																																																																																																																																																																																																																																																																																																																																
329	60	4.32	2.0	5.0	5193	286	1.45																																																																																																																																																																																																																																																																																																																																																																																																																																																
351	56	4.05	2.0	5.7	4540	250	1.66																																																																																																																																																																																																																																																																																																																																																																																																																																																
416	47	3.41	2.2	6.5	3977	219	1.89																																																																																																																																																																																																																																																																																																																																																																																																																																																
140	141	10.13	0.81	5.6	4798	253	0.84			R 107R77 RF107R77	4																																																																																																																																																																																																																																																																																																																																																																																																																																												
215	92	6.59	1.09	5.8	4647	245	0.87																																																																																																																																																																																																																																																																																																																																																																																																																																																
254	78	5.60	1.19	6.8	3945	208	1.02																																																																																																																																																																																																																																																																																																																																																																																																																																																
284	70	5.00	1.28	7.8	3433	181	1.18																																																																																																																																																																																																																																																																																																																																																																																																																																																
333	59	4.27	1.38																																																																																																																																																																																																																																																																																																																																																																																																																																																				
355	56	4.00	1.44																																																																																																																																																																																																																																																																																																																																																																																																																																																				
421	47	3.37	1.58																																																																																																																																																																																																																																																																																																																																																																																																																																																				

输出转速 Output speed r/min	输出扭矩 Output torque Nm	传动比 Ratio i	使用系数 Service factor f _s	机型号 Type Type	极数 Pole p	输出转速 Output speed r/min	输出扭矩 Output torque Nm	传动比 Ratio i	使用系数 Service factor f _s	机型号 Type Type	极数 Pole p
3.0kW						3.0kW					
3.2	8472	223.34	0.89			32	849	44.78	0.91		
3.8	7137	188.16	1.05			34	802	42.29	0.96		
4.1	6615	174.40	1.14			39	683	36.01	1.13		
4.5	5929	156.31	1.27	R 137	8	43	621	32.72	1.24		
5.0	5353	141.12	1.40	RF137	8	50	538	28.35	1.43		
5.5	4862	128.18	1.55			58	468	24.67	1.57		
6.2	4314	113.72	1.74			61	443	23.37	1.74		
6.9	3914	103.20	1.92			66	406	21.43	1.90	R 77	4
8.0	3364	88.70	2.20			76	357	18.80	2.1	RF77	4
						80	338	17.82	2.2		
						91	296	15.60	2.4		
4.3	6245	222.60	1.20			101	266	14.05	2.5		
5.1	5287	188.45	1.42			115	234	12.33	2.8		
5.5	4892	174.40	1.54	R 137	6	131	206	10.88	3.0		
6.1	4385	156.31	1.71	RF137	6	147	183	9.64	3.2		
6.8	3959	141.12	1.90			169	160	8.42	3.7		
7.5	3596	128.18	2.10			187	144	7.59	4.0		
8.4	3190	113.72	2.40			213	126	6.66	4.3		
9.3	2895	103.20	2.60								
6.2	4377	156.04	0.92	R 107	6	61	445	23.44	1.18		
6.9	3913	139.47	1.03	RF107	6	71	377	19.89	1.50		
7.6	3522	125.55	1.15			79	340	17.95	1.63		
						90	299	15.79	1.76	R 67	4
6.3	4288	226.11	0.94			95	283	14.91	1.8	RF67	4
7.1	3810	200.87	1.06			112	241	12.70	2.0		
8.5	3172	167.29	1.27			123	219	11.54	2.1		
9.1	2959	156.04	1.37			142	190	10.00	2.3		
10	2645	139.47	1.53								
11	2381	125.55	1.70	R 107	4	53	511	26.97	0.8		
12	2156	113.70	1.87	RF107	4	65	416	21.93	1.02		
14	1912	100.82	2.1			76	353	18.60	1.20		
16	1729	91.16	2.3			85	318	16.79	1.33		
18	1465	77.26	2.8			96	280	14.77	1.46		
20	1366	72.00	3.0			102	265	13.95	1.53		
						120	225	11.88	1.69		
9.4	2860	150.78	0.99			132	205	10.79	1.79	R 57	4
11	2404	126.75	1.17			152	177	9.35	2.0	RF57	4
12	2209	116.48	1.28			157	172	9.06	2.1		
14	1962	103.44	1.44			178	151	7.97	2.2		
15	1754	92.48	1.61			189	143	7.53	2.3		
17	1577	83.15	1.79			222	122	6.41	2.6		
20	1369	72.17	2.1	R 97	4	244	110	5.82	2.7		
22	1235	65.12	2.3	RF97	4	281	96	5.05	3.0		
24	1135	59.84	2.5			323	83	4.39	3.2		
27	1008	53.14	2.8								
30	901	47.51	3.1			88	308	16.22	0.84		
33	810	42.72	3.5			98	276	14.56	0.90		
38	703	37.08	4.0			113	238	12.54	0.99		
43	630	33.20	4.3			120	224	11.79	1.03		
						140	192	10.15	1.12		
15	1771	93.38	0.82			157	172	9.07	1.20		
17	1554	81.92	0.94			177	152	8.01	1.27	R 47	4
20	1373	72.37	1.06			183	147	7.76	1.04	RF47	4
22	1204	63.50	1.21			204	132	6.96	1.13		
24	1141	60.18	1.28			237	114	6.00	1.29		
27	999	52.67	1.46			252	107	5.64	1.36		
30	900	47.45	1.62			293	92	4.85	1.53		
34	790	41.63	1.85			327	82	4.34	1.67		
39	697	36.73	2.1	R 87	4	371	73	3.83	1.86		
41	651	34.34	2.2	RF87	4						
44	618	32.57	2.4			140	192	10.11	0.83		
45	592	31.22	2.5			150	180	9.47	0.87		
51	528	27.84	2.8			178	151	7.97	0.97		
53	527	27.81	2.8			213	126	6.67	1.07	R 37	4
61	444	23.40	3.3			250	108	5.67	1.24	RF37	4
66	408	21.51	3.5			281	96	5.06	1.32		
74	362	19.10	3.6			329	82	4.32	1.45		
83	324	17.08	4.0			351	77	4.05	1.49		
93	291	15.35	4.3			416	65	3.41	1.63		

R

输出转速	输出扭矩	传动比	使用系数	机型号	极数	输出转速	输出扭矩	传动比	使用系数	机型号	极数		
Output speed	Output torque	Ratio	Service factor	Type	Pole	Output speed	Output torque	Ratio	Service factor	Type	Pole		
r/min	Nm	i	f _s	Type	p	r/min	Nm	i	f _s	Type	p		
3.0kW						4.0kW							
254	106	5.60	0.88	R 27 RF27	4	3.8	8877	376	0.85	R 137R77 RF137R77	4		
284	95	5.00	0.94										
333	81	4.27	1.01										
355	76	4.00	1.05										
421	64	3.37	1.2										
109	258	6.47	4.31	RX 127 RXF127	8 8	4.2	8004	339	0.94				
220	127	6.44	1.42	RX 87 RXF87	4	4.5	7484	317	1.00				
256	110	5.55	1.92										
281	100	5.05	2.3										
316	89	4.50	3.1										
376	75	3.78	3.8										
300	94	4.73	1.24	RX 77 RXF77	4	4.8	7012	297	1.07				
351	80	4.04	1.68										
384	73	3.70	1.97										
437	64	3.25	2.7										
461	61	3.08	3.0										
377	75	3.77	1.10	RX 67 RXF67	4	5.0	6752	286	1.11				
444	63	3.20	1.49										
491	57	2.89	1.74										
559	50	2.54	2.2										
592	47	2.40	2.4										
696	40	2.04	3.1										
763	37	1.86	3.2										
882	32	1.61	3.4										
1014	28	1.40	3.5										
452	62	3.14	0.98			RX 57 RXF57	4	5.8	5902	250	1.27		
538	52	2.64	1.24										
599	47	2.37	1.38										
696	40	2.04	1.61										
740	38	1.92	1.71										
861	33	1.65	1.99										
959	29	1.48	2.2										
1092	26	1.30	2.3										
4.0kW								4.0kW					
1.7	20588	872	0.82	R 167R97 RF167R97	4			6.6	5171	219	1.45		
1.9	18179	770	0.93										
2.2	15677	664	1.08										
2.8	12041	510	1.41										
3.8	8972	380	1.89										
4.3	7980	338	2.1										
2.7	12749	540	0.96			R 147R87 RF147R87	4	7.5	4509	191	0.90		
3.1	10908	462	1.12										
3.3	10199	432	1.20										
3.9	8806	373	1.39										
4.4	7791	330	1.57										
5.1	6682	283	1.83										
5.8	5902	250	2.1										
6.7	5100	216	2.4										
7.5	4509	191	2.7										
8.9	3801	161	3.2										
2.4	14331	607	0.85	R 147R77 RF147R77	4	8.0	4273	181	0.95				
2.6	12915	547	0.95										
3.0	11333	480	1.08										
3.5	9609	407	1.27										
4.1	8452	354	1.42										
4.9	7324	302	1.67										
6.0	5946	249	2.0										
7.5	4509	191	2.3										
9.3	3860	153	2.8										
11	3318	121	3.3										
9	4172	167.29	0.97	R 137 RF137	8	12	3131	125.55	1.29				
10	3891	156.04	1.04										
11	3478	139.47	1.16										
12	3131	125.55	1.29										
13	2835	113.70	1.43										
14	2514	100.82	1.61										
16	2273	91.16	1.78										
19	1927	77.26	2.1										
20	1795	72.00	2.3										
22	1616	64.81	2.5										
25	1464	58.69	2.8										
28	1298	52.05	3.1										
12	2905	116.48	0.97	R 97 RF97	4	13	2835	113.70	1.43				
14	2579	103.44	1.09										
16	2306	92.48	1.22										
17	2073	83.15	1.36										
20	1800	72.17	1.57										
22	1624	65.12	1.74										
24	1492	59.84	1.89										
27	1325	53.14	2.1										
30	1185	47.51	2.4										
34	1065	42.72	2.6										
39	925	37.08	3.0										
43	828	33.20	3.2										
45	803	32.22	3.3										
54	669	26.84	3.6										
58	624	25.03	4.3										
64	558	22.37	4.6										
71	502	20.14	4.9										
78	455	18.24	6.2										

输出转速	输出扭矩	传动比	使用系数	机型号	极数	输出转速	输出扭矩	传动比	使用系数	机型号	极数
Output speed	Output torque	Ratio	Service factor	Type	Pole	Output speed	Output torque	Ratio	Service factor	Type	Pole
r/min	Nm	i	f _s	Type	p	r/min	Nm	i	f _s	Type	p
4.0kW						4.0kW					
23	1583	63.5	0.92			142	253	10.15	0.85		
24	1501	60.18	0.97			159	226	9.07	0.86		
27	1313	52.67	1.11			180	200	8.01	0.91		
30	1183	47.45	1.23			207	174	6.96	0.96	R 47	4
35	1038	41.63	1.40			240	150	6.00	0.98	RF47	4
39	916	36.73	1.59			255	141	5.64	1.04		
42	856	34.34	1.70			297	121	4.85	1.17		
44	812	32.57	1.79			332	108	4.34	1.27		
46	779	31.22	1.87	R 87	4	376	96	3.83	1.42		
52	694	27.84	2.1	RF87	4						
53	693	27.81	2.2			109	344	6.47	3.23	RX 127	8
62	584	23.40	2.5			121	310	5.88	3.59	RXF127	8
67	536	21.51	2.7								
75	476	19.10	3.1			147	254	6.47	4.37	RX 127	6
84	426	17.08	3.1							RXF127	6
94	383	15.35	3.3								
108	332	13.33	3.6			259	144	5.55	1.46		
121	297	11.93	3.9			285	131	5.05	1.78	RX 87	4
						320	117	4.50	2.3	RXF87	4
40	898	36.01	0.86			381	98	3.78	2.9		
44	816	32.72	0.94								
51	707	28.35	1.09			356	105	4.04	1.28		
58	615	24.67	1.19			389	96	3.70	1.50		
62	583	23.37	1.32			443	84	3.25	2.0		
67	534	21.43	1.44			468	80	3.08	2.3		
77	469	18.80	1.56			533	70	2.70	2.9		
81	444	17.82	1.65			593	63	2.43	3.2	RX 77	4
92	389	15.60	1.79	R 77	4	676	55	2.13	3.4	RXF77	4
102	350	14.05	1.93	RF77	4	766	49	1.88	3.6		
117	307	12.33	2.1			862	43	1.67	3.7		
132	271	10.88	2.3			1014	37	1.42	3.9		
149	240	9.64	2.5								
171	210	8.42	2.8			450	83	3.20	1.13		
190	189	7.59	3.0			498	75	2.89	1.33		
216	166	6.66	3.3			567	66	2.54	1.68		
245	147	5.88	3.5			600	62	2.40	1.85		
276	130	5.21	3.7			706	53	2.04	2.4	RX 67	4
						774	48	1.86	2.4	RXF67	4
						894	42	1.61	2.6		
						1029	36	1.40	2.7		
72	496	19.89	1.14								
80	448	17.95	1.24			545	69	2.64	0.95		
91	394	15.79	1.34			608	62	2.37	1.05		
97	372	14.91	1.39			706	53	2.04	1.22		
113	317	12.70	1.54			750	50	1.92	1.30	RX 57	4
125	288	11.54	1.63			873	43	1.65	1.51	RXF57	4
144	249	10.00	1.77	R 67	4	973	38	1.48	1.66		
166	217	8.70	1.91	RF67	4	1108	34	1.30	1.75		
185	194	7.79	1.84								
196	184	7.36	1.90								
230	156	6.27	2.0								
253	142	5.70	2.1								
292	123	4.93	2.2								
336	107	4.29	2.4								
77	464	18.60	0.91								
86	419	16.79	1.01			2.2	21556	664	0.80		
97	368	14.77	1.11			2.5	18764	578	0.90		
103	348	13.95	1.16			2.8	16556	510	1.02	R 167R97	4
121	296	11.88	1.29			3.3	14219	438	1.19	RF167R97	4
133	269	10.79	1.36			3.8	12336	380	1.37		
154	233	9.35	1.49	R 57	4	4.3	10973	338	1.54		
159	226	9.06	1.56	RF57	4	4.7	9966	307	1.70		
181	199	7.97	1.68			5.1	9155	282	1.85		
191	188	7.53	1.75								
225	160	6.41	1.97			3.1	14998	462	0.81		
247	145	5.82	2.1			3.3	14024	432	0.87		
285	126	5.05	2.3			3.9	12109	373	1.01		
328	109	4.39	2.4			4.4	10713	330	1.14	R 147R87	4
						5.1	9187	283	1.33	RF147R87	4
						5.8	8116	250	1.51		
						6.7	7012	216	1.74		
						7.5	6201	191	1.97		

输出转速 Output speed r/min	输出扭矩 Output torque Nm	传动比 Ratio i	使用系数 Service factor f _s	机型号 Type Type	极数 Pole p	输出转速 Output speed r/min	输出扭矩 Output torque Nm	传动比 Ratio i	使用系数 Service factor f _s	机型号 Type Type	极数 Pole p
5.5kW						5.5kW					
3.7	12752	196.41	1.32			45	1105	32.22	2.2		
4.5	10440	160.80	1.63	R 167	8	54	920	26.84	2.6		
5.5	8469	130.44	1.99	RF167	8	58	858	25.03	3.1	R 97	4
6.0	7855	120.99	2.17			64	767	22.37	3.3	RF97	4
6.9	6779	104.41	2.50			71	691	20.14	3.6		
						79	625	18.24	3.8		
						89	554	16.17	4.1		
4.4	10613	163.46	1.15	R 147	8	30	1627	47.45	0.90		
4.9	9534	146.85	1.28	RF147	8	35	1427	41.63	1.02		
6.0	7742	119.24	1.57			39	1259	36.73	1.16		
6.6	7144	110.03	1.72			44	1117	32.57	1.30		
5.9	7960	163.46	1.54	R 147	6	52	955	27.84	1.53		
6.5	7151	146.85	1.71	RF147	6	53	954	27.81	1.53		
8.0	6133	119.24	2.0			62	802	23.40	1.82	R 87	4
8.8	5659	110.03	2.2			67	738	21.51	2.0	RF87	4
10	4865	94.60	2.5			75	655	19.10	2.1		
12	4293	83.47	2.8			84	586	17.08	2.2		
5.6	8790	128.18	0.86	R 137	8	94	526	15.35	2.4		
6.3	7798	113.72	0.96	RF137	8	108	457	13.33	2.6		
7.0	7077	103.2	1.06			121	409	11.93	2.8		
8.1	6083	88.70	1.24			145	339	9.90	3.3		
						156	317	9.25	3.6		
5.5	8970	174.40	0.84	R 137	6	173	285	8.32	3.8		
6.1	8039	156.31	0.94	RF137	6	199	248	7.22	4.1		
6.8	7258	141.12	1.04			77	645	18.80	1.14		
7.5	6592	128.18	1.14			81	611	17.82	1.20		
8.4	5849	113.72	1.29			92	535	15.60	1.30		
9.3	5308	103.20	1.42			102	482	14.05	1.40		
6.4	7658	223.34	0.98	R 137	4	117	423	12.33	1.53	R 77	4
7.7	6451	188.16	1.17	RF137	4	132	373	10.88	1.66	RF77	4
8.3	5980	174.40	1.26			149	331	9.64	1.79		
9.2	5359	156.31	1.40			171	289	8.42	2.1		
10	4839	141.12	1.55			190	260	7.59	2.2		
11	4395	128.18	1.71			216	228	6.66	2.4		
13	3899	113.72	1.93			245	202	5.88	2.52		
14	3538	103.20	2.1			276	179	5.21	2.68		
16	3041	88.70	2.5			91	541	15.79	0.97		
18	2774	80.91	2.7			97	511	14.91	1.01		
20	2520	73.49	3.0			113	435	12.70	1.12		
22	2236	65.20	3.4			125	396	11.54	1.19		
24	2029	59.17	3.7			144	343	10.00	1.29	R 67	4
28	1744	50.86	4.3			166	298	8.70	1.34	RF67	4
						185	267	7.79	1.38		
11	4305	125.55	0.94	R 107	4	196	252	7.36	1.39		
13	3898	113.70	1.04	RF107	4	230	215	6.27	1.44		
14	3457	100.82	1.17			253	195	5.70	1.49		
16	3126	91.16	1.29			292	169	4.93	1.61		
19	2649	77.26	1.54			336	147	4.29	1.73		
20	2469	72.00	1.64			97	506	14.77	0.81		
22	2222	64.84	1.82			103	478	13.95	0.85		
25	2012	58.69	2.01			121	407	11.88	0.93		
28	1785	52.05	2.3			133	370	10.79	0.99		
31	1614	47.06	2.5			154	321	9.35	1.08	R 57	4
36	1367	39.88	3.0			181	273	7.97	1.22	RF57	4
						191	258	7.53	1.27		
17	2851	83.15	0.99	R 97	4	225	220	6.41	1.43		
20	2475	72.17	1.14	RF97	4	247	200	5.82	1.51		
22	2233	65.12	1.26			285	173	5.05	1.66		
24	2052	59.84	1.37			328	151	4.39	1.75		
27	1822	53.14	1.55			297	166	4.85	0.85	R 47	4
30	1629	47.51	1.73			332	149	4.34	0.92	RF47	4
34	1465	42.72	1.93			376	131	3.83	1.03		
39	1271	37.08	2.2								
43	1138	33.20	2.4								
52	944	27.54	2.7								

输出转速 Output speed r/min	输出扭矩 Output torque Nm	传动比 Ratio i	使用系数 Service factor f _s	机型号 Type Type	极数 Pole p	输出转速 Output speed r/min	输出扭矩 Output torque Nm	传动比 Ratio i	使用系数 Service factor f _s	机型号 Type Type	极数 Pole p
5.5kW						7.5kW					
116	443	6.22	3.79	RX 157 RXF157	8 8	4.4	14408	330	0.85		
						5.2	12356	283	0.99		
123	420	5.88	2.64	RX 127 RXF127	8 8	5.8	10915	250	1.12	R 147R87	4
						6.8	9431	216	1.30	RF147R87	4
147	350	6.47	3.18	RX 127	6	7.6	8339	191	1.47		
164	315	5.88	3.53	RXF127	6	9.1	7030	161	1.74		
182	283	5.28	3.92			3.7	18366	196.41	0.92		
217	238	6.65	1.82	RX 107	4	4.5	15036	160.80	1.13	R 167	4
257	200	5.60	2.14	RXF107	4	5.5	12197	130.44	1.39	RF167	4
277	186	5.19	3.52			6.0	11314	120.99	1.50		
310	166	4.65	3.93			6.9	9763	104.41	1.73		
247	208	5.82	1.9	RX 97	4	4.9	13775	196.41	1.23		
297	173	4.85	2.1	RXF97	4	6.0	11277	160.80	1.50		
319	162	4.52	3.5			7.4	9145	130.44	1.84		
356	144	4.04	3.9			7.9	8485	120.99	1.99		
396	130	3.64	4.3			9.2	7323	104.41	2.31	R 167	6
436	118	3.30	4.7			10	6462	92.14	2.6	RF167	6
493	104	2.92	5.4			12	5602	79.88	3.0		
545	94	2.64	5.9			14	4984	71.07	3.4		
643	80	2.24	7.0			15	4487	63.98	3.8		
735	70	1.96	7.6			16	4103	58.51	4.1		
878	59	1.64	8.1			4.4	15285	163.46	0.80		
1014	51	1.42	8.4			4.9	13732	146.85	0.89	R 147	8
						6.0	11150	119.24	1.09	RF147	8
						6.6	10289	110.03	1.20		
320	161	4.50	1.7	RX 87	4	5.9	11464	163.46	1.07		
381	135	3.78	2.1	RXF87	4	6.5	10299	146.85	1.19		
414	124	3.48	3.1			8.0	8363	119.24	1.45	R 147	6
466	110	3.09	3.4			8.8	7717	110.03	1.59	RF147	6
522	99	2.76	3.9			10	6635	94.60	1.84		
581	89	2.48	4.3			12	5854	83.47	2.1		
670	77	2.15	4.7			7.7	8677	188.16	0.87		
443	116	3.25	1.47	RX 77	4	8.4	8042	174.40	0.94		
468	110	3.08	1.65	RXF77	4	9.3	7208	156.31	1.04		
533	97	2.70	2.1			10	6508	141.12	1.16		
593	87	2.43	2.3			11	5911	128.18	1.27	R 137	4
676	76	2.13	2.5			13	5244	113.72	1.43	RF137	4
766	67	1.88	2.6			14	4759	103.20	1.58		
862	60	1.67	2.7			16	4090	88.70	1.84		
1014	51	1.42	2.9			18	3731	80.91	2.0		
567	91	2.54	1.22	RX 67	4	20	3389	73.49	2.2		
600	86	2.40	1.35	RXF67	4	22	3007	65.20	2.5		
706	73	2.04	1.73			25	2729	59.17	2.8		
774	66	1.86	1.78			29	2345	50.86	3.2		
894	58	1.61	1.86			16	4204	91.16	0.96		
1029	50	1.40	2.0			19	3563	77.26	1.13		
706	73	2.04	0.89	RX 57	4	20	3320	72.00	1.22		
750	69	1.92	0.95	RXF57	4	23	2989	64.81	1.35		
873	59	1.65	1.10			25	2706	58.69	1.49		
973	53	1.48	1.21			28	2400	52.05	1.68	R 107	4
1108	46	1.30	1.27			31	2170	47.06	1.86	RF107	4
7.5kW						37	1839	39.88	2.2		
2.9	22268	510	0.80	R 167R97	4	42	1607	34.84	2.5		
3.3	19124	438	0.88	RF167R97	4	48	1404	30.44	2.9		
3.8	16591	380	1.02			50	1344	29.14	3.0		
4.3	14758	338	1.15			54	1257	27.25	3.2		
4.8	13404	307	1.26			59	1134	24.60	3.6		
5.2	12313	282	1.37			65	1030	22.34	3.9		

R

输出转速	输出扭矩	传动比	使用系数	机型号	极数	输出转速	输出扭矩	传动比	使用系数	机型号	极数		
Output speed	Output torque	Ratio	Service factor	Type	Pole	Output speed	Output torque	Ratio	Service factor	Type	Pole		
r/min	Nm	i	f _s	Type	p	r/min	Nm	i	f _s	Type	p		
7.5kW						7.5kW							
24	2760	59.84	1.02	R 97 RF97	4 4	123	572	5.88	2.94	RX 127 RXF127	6 6		
27	2451	53.14	1.15			136	515	5.28	3.26				
31	2191	47.51	1.29			167	420	4.29	4.0				
34	1970	42.72	1.43			221	318	6.47	3.49	RX 127 RXF127	4 4		
39	1710	37.08	1.65			245	286	5.88	3.88				
44	1531	33.20	1.72			220	320	6.65	1.35	RX 107 RXF107	4 4		
45	1486	32.22	1.77			260	269	5.60	1.59				
53	1270	27.54	1.94			281	250	5.19	2.6				
54	1238	26.84	1.98			314	224	4.65	2.9				
58	1154	25.03	2.30			348	202	4.20	3.9				
65	1032	22.37	2.48			251	280	5.82	1.41	RX 97 RXF97	4 4		
72	929	20.14	2.64			301	233	4.85	1.59				
80	841	18.24	2.79			323	217	4.52	2.6				
40	1694	36.73	0.86			361	194	4.04	2.9				
45	1502	32.57	0.97	401	175	3.64	3.2						
52	1284	27.84	1.13	442	159	3.30	3.5	RX 87 RXF87	4 4				
53	1282	27.81	1.1	500	140	2.92	4.0						
62	1079	23.40	1.35	324	216	4.50	1.26						
68	992	21.51	1.42	386	182	3.78	1.58						
76	881	19.10	1.54	420	167	3.48	2.3						
85	788	17.08	1.66	472	149	3.09	2.6						
95	708	15.35	1.78	529	133	2.76	2.9						
110	615	13.33	1.96	589	119	2.48	3.2						
122	550	11.93	2.1	679	103	2.15	3.5						
147	457	9.90	2.4	756	93	1.93	3.6						
158	427	9.25	2.7	913	77	1.60	3.8						
175	384	8.32	2.8	1050	67	1.39	4.1						
202	333	7.22	3.0	449	156	3.25	1.09	RX 77 RXF77	4 4				
226	298	6.47	3.2	474	148	3.08	1.23						
272	247	5.36	3.5	541	130	2.70	1.56						
78	867	18.80	0.85	601	117	2.43	1.73						
82	822	17.82	0.89	685	102	2.13	1.84						
94	719	15.60	0.97	777	90	1.88	1.94						
104	648	14.05	1.04	874	80	1.67	2.0						
118	569	12.33	1.14	1028	68	1.42	2.1						
134	502	10.88	1.24	575	122	2.54	0.91			RX 67 RXF67	4 4		
151	445	9.64	1.33	608	115	2.40	1.00						
173	388	8.42	1.53	716	98	2.04	1.28						
192	350	7.59	1.64	785	89	1.86	1.32						
219	307	6.66	1.78	907	77	1.61	1.38						
248	271	5.88	1.87	1043	67	1.40	1.45						
280	240	5.21	2.00	11 kW									
115	586	12.70	0.83	R 67 RF67	4 4	4.9	18891	295	0.90	R 167R107 RF167R107	4 4		
127	532	11.54	0.88			5.1	18379	287	0.92				
146	461	10.00	0.96			5.2	17994	281	0.94				
168	401	8.70	0.99			6.1	15241	238	1.11				
187	359	7.79	1.02			7.0	13320	208	1.27				
198	339	7.36	1.03			8.3	11271	176	1.50				
233	289	6.27	1.07			4.3	21645	338	0.80			R 167R97 RF167R97	4 4
256	263	5.70	1.11			4.8	19659	307	0.86				
296	227	4.93	1.20	5.2	18059	282	0.94						
340	198	4.29	1.28	5.8	16009	250	0.80	R 147R87 RF147R87	4 4				
183	368	7.97	0.91	6.8	13832	216	0.88						
194	347	7.53	0.95	7.6	12231	191	1.00						
228	296	6.41	1.07	9.1	10310	161	1.19						
251	268	5.82	1.12	9.2	10182	159	1.20						
289	233	5.05	1.23	123	572	5.88	1.94	RX 127 RXF127	8 8				
333	202	4.39	1.30	156	449	6.22	3.74	RX 157 RXF157	6 6				

输出转速 Output speed r/min	输出扭矩 Output torque Nm	传动比 Ratio i	使用系数 Service factor f _s	机型号 Type Type	极数 Pole p	输出转速 Output speed r/min	输出扭矩 Output torque Nm	传动比 Ratio i	使用系数 Service factor f _s	机型号 Type Type	极数 Pole p
11kW						11kW					
6.0	16540	160.80	1.02			135	732	10.83	2.7		
7.4	13417	130.44	1.26	R 167	6	158	626	9.26	3.0	R 97	4
7.9	12445	120.99	1.36	RF167	6	174	566	8.37	3.4	RF97	4
9.2	10740	104.41	1.58			206	480	7.09	3.9		
						235	419	6.20	4.2		
7.4	13284	196.41	1.27			68	1455	21.51	0.97		
9.1	10876	160.80	1.56			76	1292	19.10	1.05		
11	8822	130.44	1.91	R 167	4	85	1155	17.08	1.13		
12	8183	120.99	2.07	RF167	4	95	1038	15.35	1.21		
14	7062	104.41	2.4			110	902	13.33	1.33		
16	6232	92.14	2.7			122	807	11.93	1.43	R 87	4
18	5403	79.88	3.1			147	670	9.90	1.66	RF87	4
21	4807	71.07	3.5			158	626	9.25	1.82		
						175	563	8.32	1.94		
6.5	15105	146.85	0.81			202	488	7.22	2.1		
8.1	12265	119.24	1.0	R 147	6	226	438	6.47	2.2		
8.7	11318	110.03	1.08	RF147	6	272	363	5.36	2.4		
10	9731	94.60	1.26								
12	8586	83.47	1.42			134	736	10.88	0.84		
						151	652	9.64	0.91		
8.9	11056	163.46	1.11			192	513	7.59	1.12	R 77	4
10	9932	146.85	1.23			219	450	6.66	1.21	RF77	4
12	8065	119.24	1.52			248	398	5.88	1.28		
13	7442	110.03	1.64	R 147	4	280	352	5.21	1.36		
15	6398	94.60	1.91	RF147	4						
17	5645	83.47	2.2			191	539	5.05	3.12	RX 157	6
20	4876	72.09	2.5			209	492	4.68	3.41	RXF157	6
22	4508	66.65	2.7			240	429	4.04	3.92		
24	4129	61.50	3.0								
28	3576	52.87	3.4			235	437	6.22	3.84	RX 157	4
										RXF157	4
10	9545	141.12	0.80			249	414	5.88	2.68		
11	8669	128.18	0.87			277	372	5.28	2.98	RX 127	4
13	7691	113.72	0.98			339	304	4.29	3.65	RXF127	4
14	6980	103.2	1.08			372	277	3.95	4.01		
16	5999	88.70	1.25								
18	5472	80.91	1.37	R 137	4	281	366	5.19	1.79		
20	4970	73.49	1.51	RF137	4	314	328	4.65	1.99		
22	4410	65.20	1.71			348	296	4.20	2.63		
25	4002	59.17	1.88			383	269	3.81	2.90	RX 107	4
29	3440	50.86	2.2			432	238	3.38	3.27	RXF107	4
33	3002	44.39	2.5			476	216	3.07	3.60		
39	2540	37.65	3.0			553	186	2.64	4.19		
44	2226	32.91	3.4								
23	4383	64.81	0.92			323	319	4.52	1.75		
25	3969	58.69	1.02			361	285	4.04	1.96		
28	3520	52.05	1.15			401	257	3.64	2.2		
31	3183	47.06	1.27			442	233	3.30	2.4		
37	2697	39.88	1.50			500	206	2.92	2.7	RX 97	4
42	2356	34.84	1.72	R 107	4	553	186	2.64	3.0	RXF97	4
48	2059	30.44	1.96	RF107	4	652	158	2.24	3.5		
50	1971	29.14	2.1			745	138	1.96	3.9		
54	1843	27.25	2.2			890	116	1.64	4.1		
59	1664	24.60	2.4			1028	110	1.42	4.3		
65	1511	22.34	2.7								
74	1341	19.82	3.0			420	245	3.48	1.55		
81	1217	17.99	3.3			472	218	3.09	1.75		
						529	195	2.76	1.96		
34	2889	42.72	0.98			589	175	2.48	2.2	RX 87	4
39	2508	37.08	1.12			679	152	2.15	2.4	RXF87	4
44	2245	33.20	1.21			756	136	1.93	2.5		
53	1863	27.54	1.35			913	113	1.60	2.6		
58	1693	25.03	1.57	R 97	4	1050	98	1.39	2.8		
65	1513	22.37	1.69	RF97	4						
72	1362	20.14	1.80			601	171	2.43	1.18		
80	1234	18.24	1.90			685	150	2.13	1.25	RX 77	4
90	1094	16.17	2.1			777	133	1.88	1.33	RXF77	4
100	989	14.62	2.2			874	118	1.67	1.38		
118	838	12.39	2.5			1028	100	1.42	1.46		

R

输出转速	输出扭矩	传动比	使用系数	机型号	极数	输出转速	输出扭矩	传动比	使用系数	机型号	极数				
Output speed	Output torque	Ratio	Service factor	Type	Pole	Output speed	Output torque	Ratio	Service factor	Type	Pole				
r/min	Nm	i	f _s	Type	p	r/min	Nm	i	f _s	Type	p				
15kW						15kW									
6.1	20783	238	0.81	R 167R107 RF167R107	4	53	2540	27.54	1.1	R 97 RF97	4				
6.5	19560	224	0.87			58	2309	25.03	1.15						
7.0	18163	208	0.93			65	2063	22.37	1.24						
7.5	17028	195	0.99			72	1858	20.14	1.32						
8.3	15369	176	1.10			80	1682	18.24	1.40						
7.4	18201	130.44	0.93	R 167 RF167	6	90	1491	16.17	1.51			R 87 RF87	4		
8.0	16883	120.99	1.00			100	1348	14.62	1.6						
9.2	14569	104.41	1.16			118	1143	12.39	1.8						
11	12857	92.14	1.32			135	999	10.83	2.0						
7.4	18115	196.41	0.93			158	854	9.26	2.4						
9.1	14830	160.80	1.14	174	772	8.37	2.5								
11	12030	130.44	1.41	206	654	7.09	2.9								
12	11159	120.99	1.52	235	572	6.20	3.1								
14	9630	104.41	1.76	R 167 RF167	4	85	1575	17.08	0.89	RX 157 RXF157	4				
16	8498	92.14	1.99			95	1416	15.35	0.98						
18	7367	79.88	2.3			110	1229	13.33	1.05						
21	6555	71.07	2.6			122	1100	11.93	1.13						
23	5901	63.98	2.9			147	913	9.90	1.21						
25	5396	58.51	3.1			158	853	9.25	1.33						
8.8	15353	110.03	0.80			175	767	8.32	1.42						
10	13200	94.60	0.93			202	666	7.22	1.51						
12	11647	83.47	1.05			226	597	6.47	1.61						
13	10059	72.09	1.21			272	494	5.36	1.73						
14	9300	66.65	1.31	R 147 RF147	6	287	488	5.05	3.44			RX 127 RXF127	4		
8.9	15076	163.46	0.81			315	446	4.68	3.77						
9.9	13544	146.86	0.90			361	388	4.04	3.32						
12	10997	119.24	1.11			372	378	3.95	2.94						
13	10148	110.03	1.20			R 147 RF147	4	281	479	5.19	1.36			RX 107 RXF107	4
15	8725	94.60	1.40					314	429	4.65	1.52				
17	7698	83.47	1.59					348	387	4.20	2.0				
20	6649	72.09	1.84					383	351	3.81	2.2				
22	6147	66.65	1.99					432	325	3.38	2.4				
24	5631	61.50	2.2					476	295	3.07	2.6				
28	4876	52.87	2.5	553	254			2.64	3.1						
31	4303	46.65	2.8	635	221			2.30	3.5						
14	9518	103.2	0.8	749	188			1.95	3.8						
16	8181	88.70	0.92	854	164			1.71	4.0						
18	7462	80.91	1.01	1014	138	1.44	4.4								
20	6778	73.49	1.11	R 137 RF137	4	323	435	4.52	1.3	RX 97 RXF97	4				
22	6013	65.20	1.25			361	388	4.04	1.4						
25	5457	59.17	1.38			401	350	3.64	1.6						
29	4691	50.86	1.60			442	317	3.30	1.8						
33	4094	44.39	1.84			500	281	2.92	2.0						
39	3472	37.65	2.2			553	254	2.64	2.2						
44	3035	32.91	2.5			652	215	2.24	2.6						
52	2567	27.83	2.9			745	188	1.96	2.8						
31	4340	47.06	0.9			890	158	1.64	3.0						
37	3678	39.88	1.10			1028	137	1.42	3.1						
42	3213	34.84	1.26	R 107 RF107	4	420	335	3.48	1.14			RX 87 RXF87	4		
48	2807	30.44	1.44			472	297	3.09	1.28						
50	2688	29.14	1.50			529	265	2.76	1.43						
54	2513	27.25	1.61			589	238	2.48	1.60						
59	2269	24.60	1.78			679	207	2.15	1.75						
65	2060	22.34	1.96			756	186	1.93	1.80						
74	1828	19.82	2.2			913	154	1.60	1.92						
81	1659	17.99	2.4			1050	134	1.39	2.0						
94	1426	15.46	2.8												
108	1245	13.50	3.2												

R

输出转速	输出扭矩	传动比	使用系数	机型号	极数	输出转速	输出扭矩	传动比	使用系数	机型号	极数
Output speed	Output torque	Ratio	Service factor	Type	Pole	Output speed	Output torque	Ratio	Service factor	Type	Pole
r/min	Nm	i	f _s	Type	p	r/min	Nm	i	f _s	Type	p
18.5kW						18.5kW					
9.1	18291	160.80	0.93	R 167 RF167	4	110	1516	13.33	0.8	R 87 RF87	4
11	14838	130.44	1.13			122	1357	11.93	0.85		
12	13763	120.99	1.24			147	1126	9.90	0.98		
14	11877	104.41	1.42			158	1052	9.25	1.08		
16	10481	92.14	1.61			175	946	8.32	1.15		
18	9086	79.88	1.86			202	821	7.22	1.22		
21	8084	71.07	2.1			226	736	6.47	1.30		
23	7278	63.98	2.3			272	610	5.36	1.40		
25	6655	58.51	2.5								
29	5791	50.91	2.9								
						317	547	4.68	3.07	RX 157	4
						364	476	4.04	3.53	RXF157	4
						412	420	3.57	4.0		
12	13564	119.24	0.90	R 147 RF147	4	348	478	4.20	1.63	RX 107 RXF107	4
13	12516	110.03	0.98			383	452	3.81	1.73		
15	10761	94.60	1.14			432	401	3.38	1.95		
17	9495	83.47	1.29			476	364	3.07	2.1		
20	8200	72.09	1.49			553	313	2.64	2.5		
22	7581	66.65	1.61			635	273	2.30	2.9		
24	6944	61.50	1.76			749	231	1.95	3.1		
28	6014	52.87	2.0			854	203	1.71	3.3		
31	5306	46.65	2.3			1014	171	1.44	3.6		
36	4583	40.29	2.7								
18	9203	80.91	0.82	R 137 RF137	4	401	432	3.64	1.30	RX 97 RXF97	4
20	8359	73.49	0.90			442	391	3.30	1.43		
22	7416	65.20	1.01			500	346	2.92	1.62		
25	6731	59.17	1.12			553	313	2.64	1.79		
29	5785	50.86	1.30			652	266	2.24	2.1		
33	5049	44.39	1.49			745	232	1.96	2.3		
39	4283	37.65	1.76			890	194	1.64	2.4		
44	3744	32.91	2.0			1028	168	1.42	2.5		
49	3362	29.56	2.2								
52	3166	27.83	2.3								
61	2730	24.00	2.7								
66	2520	22.15	3.0								
77	2166	19.04	3.5								
87	1911	16.80	3.9								
37	4536	39.88	0.89	R 107 RF107	4	529	327	2.76	1.16	RX 87 RXF87	4
42	3963	34.84	1.02			589	294	2.48	1.29		
50	3315	29.14	1.22			679	255	2.15	1.42		
59	2798	24.60	1.44			756	229	1.93	1.46		
65	2541	22.34	1.59			913	190	1.60	1.56		
74	2255	19.82	1.79			1050	165	1.39	1.65		
81	2046	17.99	1.98								
94	1759	15.46	2.3								
108	1536	13.50	2.3								
128	1302	11.45	3.1								
146	1139	10.01	3.5								
181	918	8.07	3.0								
213	778	6.84	3.6								
72	2291	20.14	1.07	R 97 RF97	4	22kW					
80	2075	18.24	1.13			11	17645	130.44	0.95		
90	1839	16.17	1.23			12	16366	120.99	1.04		
100	1663	14.62	1.30			14	14124	104.41	1.20		
118	1409	12.39	1.46			16	12464	92.14	1.36		
135	1232	10.83	1.59			18	10805	79.88	1.57		
158	1053	9.26	1.81			21	9614	71.07	1.76	R 167	
174	952	8.37	2.0			23	8655	63.98	2.0	RF167	
206	806	7.09	2.3			25	7915	58.51	2.1		
235	705	6.20	2.5			29	6887	50.91	2.5		
282	589	5.18	2.8	32	6078	44.93	2.8				
328	511	4.49	3.0	37	5269	38.95	3.2				
						13	14884	110.03	0.83	R 147 RF147	4
						15	12797	94.60	0.95		
						17	11291	83.47	1.08		
						20	9752	72.09	1.3		
						22	9016	66.65	1.36		
						24	8258	61.50	1.48		
						28	7152	52.87	1.71		
						31	6310	46.65	1.94		
						36	5450	40.29	2.2		
						41	4821	35.64	2.5		
						49	4051	29.95	3.0		

R

输出转速 Output speed r/min	输出扭矩 Output torque Nm	传动比 Ratio i	使用系数 Service factor f _s	机型号 Type Type	极数 Pole p	输出转速 Output speed r/min	输出扭矩 Output torque Nm	传动比 Ratio i	使用系数 Service factor f _s	机型号 Type Type	极数 Pole p
22kW						22kW					
22	8820	65.20	0.85			652	316	2.24	1.77		
25	8004	59.17	0.94			745	276	1.96	1.94	RX 97	4
29	6880	50.86	1.09			890	231	1.64	2.05	RXF97	4
33	6005	44.39	1.25			1028	200	1.42	2.14		
39	5093	37.65	1.48								
44	4452	32.91	1.69								
49	3999	29.56	1.88	R 137	4	529	389	2.76	0.98		
52	3765	27.83	2.00	RF137	4	589	350	2.48	1.09		
61	3246	24.00	2.3			679	303	2.15	1.19	RX 87	4
66	2996	22.15	2.5			756	272	1.93	1.23	RXF87	4
77	2576	19.04	2.9			913	226	1.60	1.31		
87	2273	16.80	3.3			1050	196	1.39	1.39		
101	1963	14.51	3.8								
114	1736	12.83	4.3								
30kW						30kW					
42	4713	34.84	0.86			16	16996	92.14	1.0		
50	3942	29.14	1.03			18	14735	79.88	1.15		
59	3328	24.60	1.21			21	13109	71.07	1.29		
65	3022	22.34	1.34			23	11802	63.98	1.43		
74	2681	19.82	1.51			25	10793	58.51	1.57		
81	2434	17.99	1.66			29	9391	50.91	1.80	R 167	4
94	2091	15.46	1.93	R 107	4	32	8288	44.93	2.04	RF167	4
108	1826	13.50	2.2	RF107	4	37	7185	38.95	2.4		
128	1549	11.45	2.6			42	6393	34.66	2.6		
146	1354	10.01	2.7			49	5510	29.87	3.1		
173	1144	8.46	2.9			60	4477	24.27	3.8		
181	1092	8.07	3.0			71	3796	20.58	4.5		
213	925	6.84	3.2								
244	809	5.98	3.5			17	15397	83.47	0.8		
						20	13298	72.09	0.92		
						22	12294	66.65	0.99		
						24	11261	61.50	1.09		
						28	9752	52.87	1.25		
						31	8605	46.65	1.42	R 147	4
						36	7432	40.29	1.64	RF147	4
						41	6574	35.64	1.86		
						49	5525	29.95	2.2		
						60	4462	24.19	2.5		
						71	3770	20.44	3.0		
						81	3328	18.04	3.0		
						93	2885	15.64	4.2		
						29	9382	50.86	0.80		
						33	8188	44.39	0.92		
						39	6945	37.65	1.08		
						44	6071	32.91	1.24		
						52	5133	27.83	1.41		
						61	4427	24.00	1.69		
						66	4086	22.15	1.85	R 137	4
						77	3512	19.04	2.1	RF137	4
						87	3099	16.80	2.4		
						101	2676	14.51	2.8		
						114	2367	12.83	3.2		
						135	1990	10.79	3.8		
						192	1400	7.59	3.4		
						229	1177	6.38	4.1		
						74	3656	19.82	1.11		
						81	3318	17.99	1.22		
						94	2852	15.46	1.42		
						108	2490	13.50	1.62		
						128	2112	11.45	1.88		
						146	1846	10.01	1.91	R 107	4
						173	1561	8.46	2.2	RF107	4
						181	1489	8.07	2.2		
						213	1262	6.84	2.5		
						244	1103	5.98	2.6		
						289	933	5.06	2.9		

R

输出转速	输出扭矩	传动比	使用系数	机型号	极数	输出转速	输出扭矩	传动比	使用系数	机型号	极数
Output speed	Output torque	Ratio	Service factor	Type	Pole	Output speed	Output torque	Ratio	Service factor	Type	Pole
r/min	Nm	i	f _s	Type	p	r/min	Nm	i	f _s	Type	p
30kW						37kW					
100	2697	14.62	0.80			39	8507	37.65	0.88		
118	2285	12.39	0.90			45	7436	32.91	1.01		
135	1998	10.83	0.98			53	6288	27.83	1.20		
158	1708	9.26	1.12			61	5423	24.00	1.38		
174	1544	8.37	1.24	R 97	4	67	5005	22.15	1.51		
206	1308	7.09	1.44	RF97	4	77	4302	19.04	1.75	R 137	4
235	1144	6.20	1.55			88	3796	16.80	1.98	RF137	4
282	955	5.18	1.75			101	3279	14.51	2.3		
325	828	4.49	1.85			115	2899	12.83	2.6		
						136	2438	10.79	2.8		
						169	1968	8.71	3.1		
432	649	3.40	1.71	RX 127	4	194	1715	7.59	3.3		
				RXF127	4	230	1442	6.38	3.7		
						285	1164	5.15	3.7		
432	623	3.38	1.25			74	4478	19.82	0.90		
476	566	3.07	1.38			82	4065	17.99	0.99		
553	487	2.64	1.60	RX 107	4	95	3493	15.46	1.16		
635	424	2.30	1.84	RXF107	4	109	3050	13.50	1.33		
749	360	1.95	2.0			128	2587	11.45	1.50		
854	315	1.71	2.1			147	2262	10.01	1.56	R 107	4
1014	266	1.44	2.3			174	1912	8.46	1.79	RF107	4
						182	1823	8.07	1.8		
500	539	2.92	1.04			215	1546	6.84	2.1		
553	487	2.64	1.15			246	1351	5.98	2.1		
652	413	2.24	1.35	RX 97	4	291	1143	5.06	2.4		
745	362	1.96	1.48	RXF97	4						
890	303	1.64	1.57								
1028	262	1.42	1.63								
37kW						432	801	3.40	1.39	RX 127	4
18	18049	79.88	0.94			490	707	3.00	1.57	RXF127	4
21	16058	71.07	1.05			568	610	2.59	1.82		
23	14456	63.98	1.17								
25	13220	58.51	1.28			435	796	3.38	0.98		
29	11503	50.91	1.47			479	723	3.07	1.08		
33	10152	44.93	1.67	R 167	4	557	622	2.64	1.25	RX 107	4
38	8801	38.95	1.92	RF167	4	639	542	2.30	1.44	RXF107	4
42	7831	34.66	2.16			754	459	1.95	1.57		
49	6749	29.87	2.5			860	403	1.71	1.65		
61	5484	24.27	3.1			1021	339	1.44	1.79		
78	4232	18.73	4.0								
90	3685	16.31	4.6								
101	3290	14.56	5.1								
						45kW					
22	15060	66.65	0.81			23	17463	63.98	0.97		
24	13794	61.50	0.89			25	15970	58.51	1.06		
28	11946	52.87	1.02			29	13896	50.91	1.22		
32	10541	46.65	1.16			33	12264	44.93	1.38		
36	9104	40.29	1.34			38	10631	38.95	1.59		
41	8053	35.64	1.52	R 147	4	43	9460	34.66	1.79		
49	6767	29.95	1.81	RF147	4	50	8153	29.87	2.08	R 167	4
61	5466	24.19	2.0			61	6624	24.27	2.4	RF167	4
72	4618	20.44	2.4			72	5617	20.58	2.6		
81	4076	18.04	2.4			79	5112	18.73	3.0		
94	3534	15.64	3.5			91	4452	16.31	3.4		
106	3143	13.91	3.8			102	3974	14.56	3.5		
						28	14431	52.87	0.85		
						32	12733	46.65	0.96		
						37	10997	40.29	1.11		
						42	9728	35.64	1.26		
						49	8175	29.95	1.49		
						61	6603	24.19	1.69		
						72	5579	20.44	2.0	R 147	4
						82	4924	18.04	2.0	RF147	4
						95	4269	15.64	2.9		
						106	3797	13.91	3.2		
						123	3273	11.99	3.7		
						204	1979	7.25	4.1		

R

输出转速	输出扭矩	传动比	使用系数	机型号	极数	输出转速	输出扭矩	传动比	使用系数	机型号	极数
Output speed	Output torque	Ratio	Service factor	Type	Pole	Output speed	Output torque	Ratio	Service factor	Type	Pole
r/min	Nm	i	f _B	Type	p	r/min	Nm	i	f _B	Type	p
45kW						55kW					
45	8983	32.91	0.84			78	6352	19.04	1.18		
53	7596	27.83	0.99			88	5605	16.80	1.34		
62	6551	24.00	1.15			102	4841	14.51	1.55		
67	6046	22.15	1.24			115	4280	12.83	1.76	R 137	4
78	5197	19.04	1.45			137	3600	10.79	1.90	RF137	4
88	4586	16.80	1.64	R 137	4	170	2906	8.71	2.1		
102	3960	14.51	1.90	RF137	4	195	2532	7.59	2.3		
115	3502	12.83	2.1			232	2128	6.38	2.5		
137	2945	10.79	2.3			287	1718	5.15	2.5		
170	2377	8.71	2.6			415	1242	3.57	1.35	RX 157	4
195	2072	7.59	2.8			479	1075	3.09	1.56	RXF157	4
232	1741	6.38	3.1								
287	1406	5.15	3.1								
75kW						55kW					
96	4220	15.46	0.96			38	17719	38.95	0.95		
110	3685	13.50	1.10			43	15767	34.66	1.07		
129	3125	11.45	1.27			50	13588	29.87	1.25		
148	2732	10.01	1.29			61	11041	24.27	1.43		
175	2309	8.46	1.48	R 107	4	72	9362	20.58	1.53	R 167	4
183	2203	8.07	1.50	RF107	4	79	8521	18.73	1.81	RF167	4
216	1867	6.84	1.71			91	7420	16.31	2.03		
247	1632	5.98	1.75			102	6624	14.56	2.13		
292	1381	5.06	2.0			119	5646	12.41	3.0		
435	968	3.40	1.15			144	4677	10.28	3.4		
493	854	3.00	1.30			169	3990	8.77	4.0		
571	737	2.59	1.51	RX 127	4						
646	652	2.29	1.70	RXF127	4						
767	549	1.93	2.02			49	13625	29.95	0.90		
438	962	3.38	0.81			61	11004	24.19	1.11		
482	874	3.07	0.89			72	9298	20.44	1.20		
561	751	2.64	1.04			82	8207	18.04	1.21		
643	654	2.30	1.19	RX 107	4	95	7115	15.64	1.72	R 147	4
759	555	1.95	1.30	RXF107	4	106	6328	13.91	1.87	RF147	4
865	487	1.71	1.36			123	5454	11.99	2.2		
1028	410	1.44	1.48			152	4431	9.74	2.5		
						179	3758	8.26	2.8		
						204	3298	7.25	3.0		
						251	2679	5.89	3.3		
						296	2275	5.00	3.6		
55kW						55kW					
29	16984	50.91	1.00			479	1466	3.09	1.15		
33	14989	44.93	1.13			538	1304	2.75	1.29	RX 157	4
38	12984	38.95	1.30			624	1124	2.37	1.49	RXF157	4
43	11563	34.66	1.46			767	915	1.93	1.84		
50	9963	29.87	1.70			767	915	1.93	1.21	RX 127	4
61	8097	24.27	1.96	R 167	4	949	740	1.56	1.50	RXF127	4
61	8097	24.27	1.96	RF167	4						
72	6866	20.58	2.09								
79	6248	18.73	2.50								
91	5441	16.31	2.76								
102	4857	14.56	2.90								
119	4140	12.41	4.09								
144	3429	10.28	4.66								
90kW						90kW					
32	15563	46.65	0.8			43	18921	34.66	0.89		
37	13441	40.29	0.91			50	16306	29.87	1.04		
42	11890	35.64	1.03			61	13249	24.27	1.20		
49	9991	29.95	1.22			72	11235	20.58	1.28		
61	8070	24.19	1.39			79	10225	18.73	1.51	R 167	4
72	6819	20.44	1.65			91	8904	16.31	1.69	RF167	4
82	6018	18.04	1.64	R 147	4	102	7947	14.56	1.77		
95	5218	15.64	2.3	RF147	4	119	6775	12.41	2.5		
106	4640	13.91	2.6			144	5612	10.28	2.8		
123	4000	11.99	3.1			169	4788	8.77	3.3		
152	3249	9.74	3.8								
204	2419	7.25	3.4								
251	1965	5.89	4.1								

输出转速	输出扭矩	传动比	使用系数	机型号	极数	输出转速	输出扭矩	传动比	使用系数	机型号	极数
Output speed	Output torque	Ratio	Service factor	Type	Pole	Output speed	Output torque	Ratio	Service factor	Type	Pole
r/min	Nm	i	f _s	Type	p	r/min	Nm	i	f _s	Type	p
90kW											
72	11158	20.44	1.01								
82	9848	18.04	1.10								
95	8538	15.64	1.43								
106	7593	13.91	1.56								
123	6545	11.99	1.87	R 147	4						
156	5170	9.47	2.1	RF147	4						
179	4509	8.26	2.4								
204	3958	7.25	2.5								
251	3215	5.89	2.7								
296	2729	5.00	3.0								
542	1555	2.75	1.08	RX 157	4						
629	1340	2.37	1.25	RXF157	4						
772	1091	1.93	1.54								
955	882	1.56	1.26	RX 127	4						
				RXF127	4						
110kW											
61	16193	24.27	1.04								
72	13731	20.58	1.23								
91	10882	16.31	1.38								
102	9715	14.56	1.45	R 167	4						
119	8280	12.41	2.04	RF167	4						
144	6859	10.28	2.3								
169	5851	8.77	2.7								
629	1638	2.37	1.03	RX 157	4						
772	1334	1.93	1.26	RXF157	4						
914	1126	1.63	1.49								
132kW											
72	16477	20.58	1.03								
91	13059	16.31	1.15								
102	11657	14.56	1.21	R 167	4						
119	9936	12.41	1.70	RF167	4						
144	8231	10.28	1.94								
169	7022	8.77	2.28								
914	1351	1.63	1.24	RX 157	4						
				RXF157	4						
160kW											
120	11963	12.41	1.41	R 167	4						
145	9910	10.28	1.61	RF167	4						
170	8484	8.77	1.89								

R

Mamax Permissible torque Nm	输出转速 Output speed r/min	传动比 Ratio i	机 型 号 Type Type	功率 Power kW/4p	Mamax Permissible torque Nm	输出转速 Output speed r/min	传动比 Ratio i	机 型 号 Type Type	功率 Power kW/4p		
130	8.5	164	R 27R17 RF27R17	0.18	1550	0.82	1690	R 87R57 RF87R57	0.18		
	8.9	156				0.91	1524				
	10	135				1.0	1395				
	12	118				1.1	1232				
	13	104				1.2	1145				
15	90	1.3	1037								
200	4.8	289	R 37R17 RF37R17	0.18		1.6	883			R 87R57 RF87R57	0.37
	5.7	243				1.7	802				
	6.2	226				1.8	754				
	7.5	185				1.4	1008				
	8.5	164			2.0	683					
8.9	156	2.3	599	0.55							
10	135	2.6	538								
11	127	2.9	472								
13	104	3.4	400								
15	90	3.5	396								
300	3.2	429	R 47R37 RF47R37	0.18	3.9	361	R 87R57 RF87R57	0.75			
	3.7	372			4.0	351					
	4.0	348			4.6	305					
	4.6	301			4.7	300					
	5.5	255			5.2	267			1.1		
6.1	228	5.5	256								
450	2.1	678	R 57R37 RF57R37	0.18	0.32	4309				R 97R57 RF97R57	0.18
	2.4	589			0.35	4004					
	2.6	537			0.38	3702					
	3.0	471			0.40	3481					
	3.9	357			0.46	3019					
4.4	319	0.52	2668	0.25							
5.2	267	0.62	2245								
5.8	241	0.69	2016								
600	1.7	836	R 67R37 RF67R37		0.18	0.76	1823	R 97R57 RF97R57	0.37		
	1.9	750				0.80	1733				
	2.0	730		0.86		1623					
	2.2	630		0.88		1583					
	2.4	571		0.97		1434					
2.5	561	1.00	1396								
600	2.8	495	R 77R37 RF77R37	0.25	1.1	1228	R 97R57 RF97R57			0.55	
	2.9	486			1.2	1207					
	3.2	438			1.3	1084					
	3.6	388			1.3	1068					
	4.1	336			1.5	937					
4.8	287	1.5	934								
820	1.2	1124	R 77R37 RF77R37	0.18	1.6	878		R 97R57 RF97R57	0.75		
	1.3	1047			1.7	824					
	1.5	915			1.8	755					
	1.6	858			1.9	737					
	1.8	757			2.1	631					
820	2.1	671	R 77R37 RF77R37	0.25	2.2	625	R 97R57 RF97R57			1.1	
	2.4	571			2.5	549					
	2.5	547			2.6	560					
	2.9	477			2.9	484					
	3.3	426			3.2	430					
1550	3.8	364	R 87R57 RF87R57	0.37	3.7	379		R 97R57 RF97R57	1.5		
	4.5	312			4.1	336					
	4.5	310			4.7	296					
	5.6	248			5.1	270					
	1550	0.65			2129	R 87R57 RF87R57					0.18
0.71		1955	5.9	234							
0.72		1930	6.1	227							
0.79		1737									
0.80		1733									

表上所配功率均有超载,按实际条件确定的转矩不得大于减速机额定转矩。 The power are all overload in the table. The decided torque according to operating condition should not more than gear units' nominal torque.

Mamax Permissible torque	输出转速 Output speed	传动比 Ratio	机 型 号 Type	功率 Power	Mamax Permissible torque	输出转速 Output speed	传动比 Ratio	机 型 号 Type	功率 Power
Nm	r/min	i	Type	kW/4p	Nm	r/min	i	Type	kW/4p
4300	0.21	6690	R 107R77 RF107R77	0.18	8000	0.34	4018	R 137R77 RF137R77	0.37
	0.24	5735				0.35	3928		
	0.27	5127				0.40	3514		
	0.32	4302				0.41	3377		
	0.36	3870				0.42	3338		
	0.36	3847		0.47		2929	0.55		
	0.42	3302		0.48		2926			
	0.46	3015		0.52		2658			
	0.46	2997		0.56		2484			
	0.53	2621		0.58		2412			
	0.62	2252		0.37		0.62	2242		
	0.68	2041				0.67	2073		
	0.71	1971				0.75	1863		0.75
	0.77	1813				0.76	1839		
	0.83	1673				0.88	1598		
	0.88	1587		1.0		1397			
	0.91	1531		1.1		1226			
	1.00	1390		0.55		1.3	1090		
	1.00	1389				1.3	1080		
	1.14	1216				1.4	1020		
	1.2	1194				1.5	951		
	1.27	1095				1.6	869		
	1.3	1043		0.75		1.7	831		
	1.50	927				2.0	730		
	1.6	888				2.1	684		
	1.7	787				2.3	629		
	2.0	692				2.3	609		
	2.3	605		1.5		2.6	564		
	2.4	598				2.6	549		
	2.6	530				2.8	517		
2.7	510	2.9	490						
2.9	479	3.2	453						
3.1	463	2.2	3.4	428					
3.4	420		3.8	376					
3.5	406		3.8	374					
3.8	373		4.2	339					
4.0	357		4.5	317					
4.5	321	3	4.8	297					
4.6	313		5.0	286					
5.1	281		5.8	250					
5.2	277		0.18	0.08	18210				
5.7	253			0.09	15923				
5.8	245	0.10		14075					
6.6	217	0.12		12344					
6.9	208	0.13		11143					
7.5	191	4	0.15	9743					
7.9	181		0.17	8443					
8.6	167		0.20	7307					
8000	0.12		11712	0.22	6447				
	0.13		10573	0.26	5568				
	0.16	8784	0.30	4815					
	0.19	7479	0.33	4325					
	0.22	6412	0.39	3669					
	0.24	5834	0.44	3228					
	0.28	5001	0.50	2833					
	0.30	4709	0.37	R 147R77 RF147R77					
	0.32	4364							

R

表上所配功率均有超载,按实际条件确定的转矩不得大于减速机额定转矩。 The power are all overload in the table.The decided torque according to operating condition should not more than gear units' nominal torque.

Mamax Permissible torque Nm	输出转速 Output speed r/min	传动比 Ratio i	机 型 号 Type Type	功率 Power kW/4p	Mamax Permissible torque Nm	输出转速 Output speed r/min	传动比 Ratio i	机 型 号 Type Type	功率 Power kW/4p	
13000	0.56	2555	R 147R77 RF147R77	1.1		4.9	295	R 167R107 RF167R107	11	
	0.65	2211				5.1	287			
	0.73	1951				5.2	281			
	0.84	1705		1.5		5.6	260			
	0.93	1536				6.1	238			
	1.1	1329				6.5	224			
	1.2	1166	2.2	7.0		208				
	1.4	1029		7.5		195				
	1.6	889		3						
	1.8	784								
	2.1	695	4							
	2.4	607								
	2.6	547		5.5						
	3.0	480								
	2.7	540	4							
	3.1	462								
	3.3	432		R 147R87		5.5				
	3.9	373	RF147R87	7.5						
4.4	330									
6.8	216				11					
18000	0.05	27001		0.55		0.06	22482	R 167R97 RF167R97		
	0.07	20002				0.08	17361			
	0.08	17361				0.09	15446			
	0.09	15446				0.10	14051			
	0.10	14051				0.12	11812			
	0.12	11812				0.13	10519			
	0.13	10519				0.14	9754			
	0.14	9754				0.23	6069			
	0.23	6069				0.75	0.26			5399
	0.26	5399					0.30			4709
	0.30	4709					0.33			4182
	0.33	4182				1.1	0.18			7749
	0.18	7749	0.20	6894						
	0.20	6894	0.37	3739						
	0.37	3739	1.5	0.54		2657				
	0.54	2657		0.61		2333				
	0.61	2333		0.69		2085				
	0.69	2085	2.2	0.76		1877				
	0.76	1877		0.86		1670				
	0.86	1670		0.98		1456				
	0.98	1456	3	1.1		1296				
	1.1	1296		1.3		1137				
	1.3	1137		1.4		1012				
	1.4	1012	4	1.7		872				
1.7	872	1.9		770						
1.9	770	5.5		2.2	664					
2.2	664		2.5	578						
2.5	578		7.5	2.8	510					
2.8	510	3.3		438						
3.3	438	3.8		380						
3.8	380	11	4.3	338						
4.3	338		4.8	307						
4.8	307		5.2	282						
5.2	282									

表上所配功率均有超载,按实际条件确定的转矩不得大于减速机额定转矩。 The power are all overload in the table. The decided torque according to operating condition should not more than gear units' nominal torque.

RX37

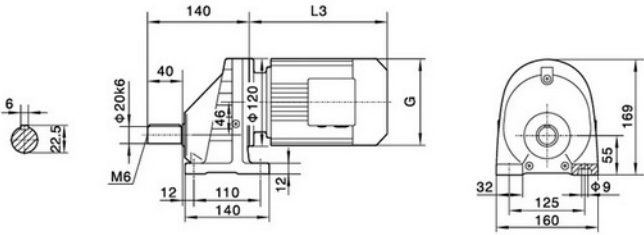

RX..S37

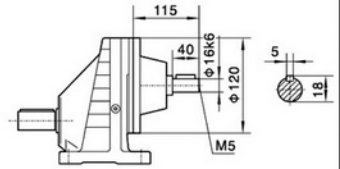

RXF37

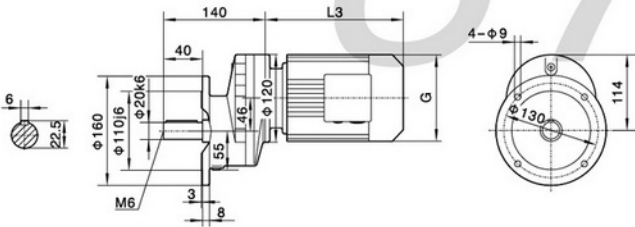

电机需方配时或配特殊电机时需加联接法兰
When equipping the user's motor or the special one, the flange is required to be connected.

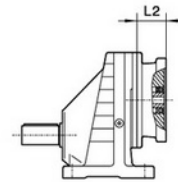

注：其余尺寸见相应的结构形式
Note: For other values please refer to the oppsited structure

Y ₂ 电机座号 Motor size	63	71	80	90S	
功率/HP Power/(kW)	0.18	0.25 0.37	0.55 0.75	1.1	
L3	223	236	264	301	
G	130	145	175	195	
L2	71	71	71	71	

注：“RX..”表示RX、RXF
Note:“RX..”mean RX、RXF

RX57

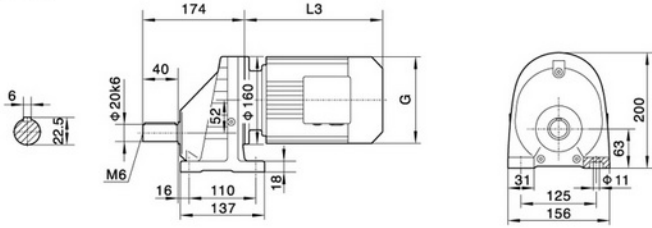

RX..S57

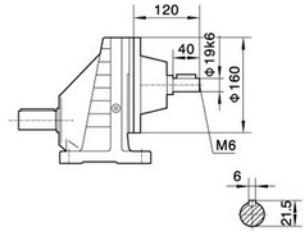

RXF57

Φ 140

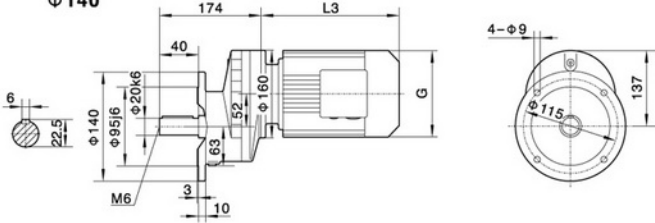

Φ 160

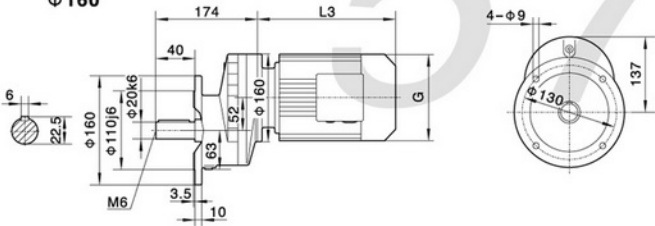

Φ 200

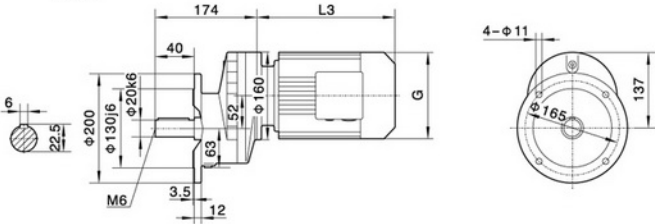

电机需方配时或配特殊电机时需加联接法兰
When equipping the user's motor or the special one, the flange is required to be connected.

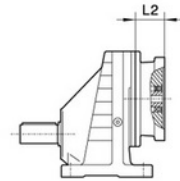

注：其余尺寸见相应的结构形式
Note: For other values please refer to the oppsited structure

Y ₂ 电机机座号 Motor size	63	71	80	90S	90L	100	112M	132S	
功率/4P Power/(kW)	0.18	0.25 0.37	0.55 0.75	1.1	1.5	2.2 3.0	4.0	5.5	
L3	223	245	278	304	328	350	380	425	
G	130	145	175	195	195	215	240	275	
L2	81	81	81	81	81	93	93	101	

注：“RX..”表示RX、RXF

Note：“RX..”mean RX、RXF

RX67

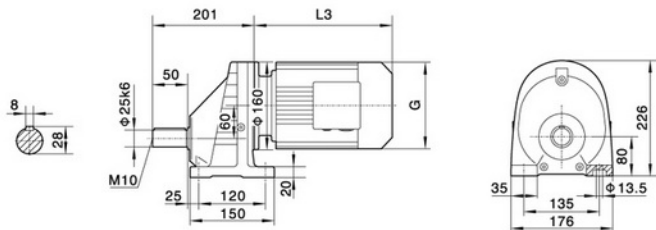

RX..S67

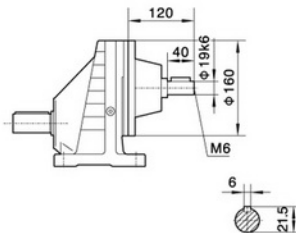

RXF67

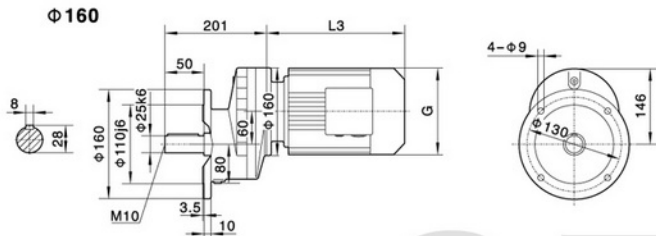

电机需方配时或配特殊电机时需加联接法兰
When equipping the user's motor or the special one, the flange is required to be connected.

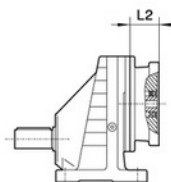
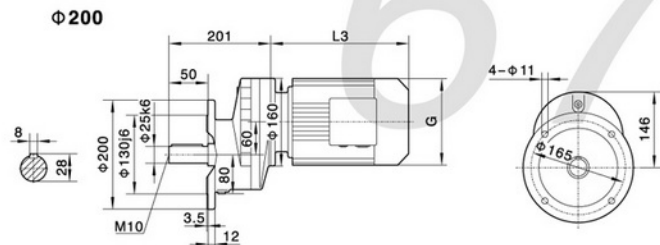

注：其余尺寸见相应的结构形式
Note: For other values please refer to the oppsited structure

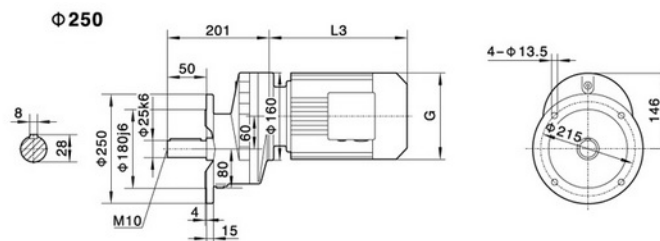

Y ₂ 电机机座号 Motor size	63	71	80	90S	90L	100	112M	132S	132M	
功率/4P Power/(kW)	0.18	0.25 0.37	0.55 0.75	1.1	1.5	2.2 3.0	4.0	5.5	7.5	
L3	223	245	278	304	328	350	380	425	461	
G	130	145	175	195	195	215	240	275	275	
L2	81	81	81	81	81	93	93	101	101	

注：“RX..”表示RX、RFX

Note：“RX..”mean RX、RFX

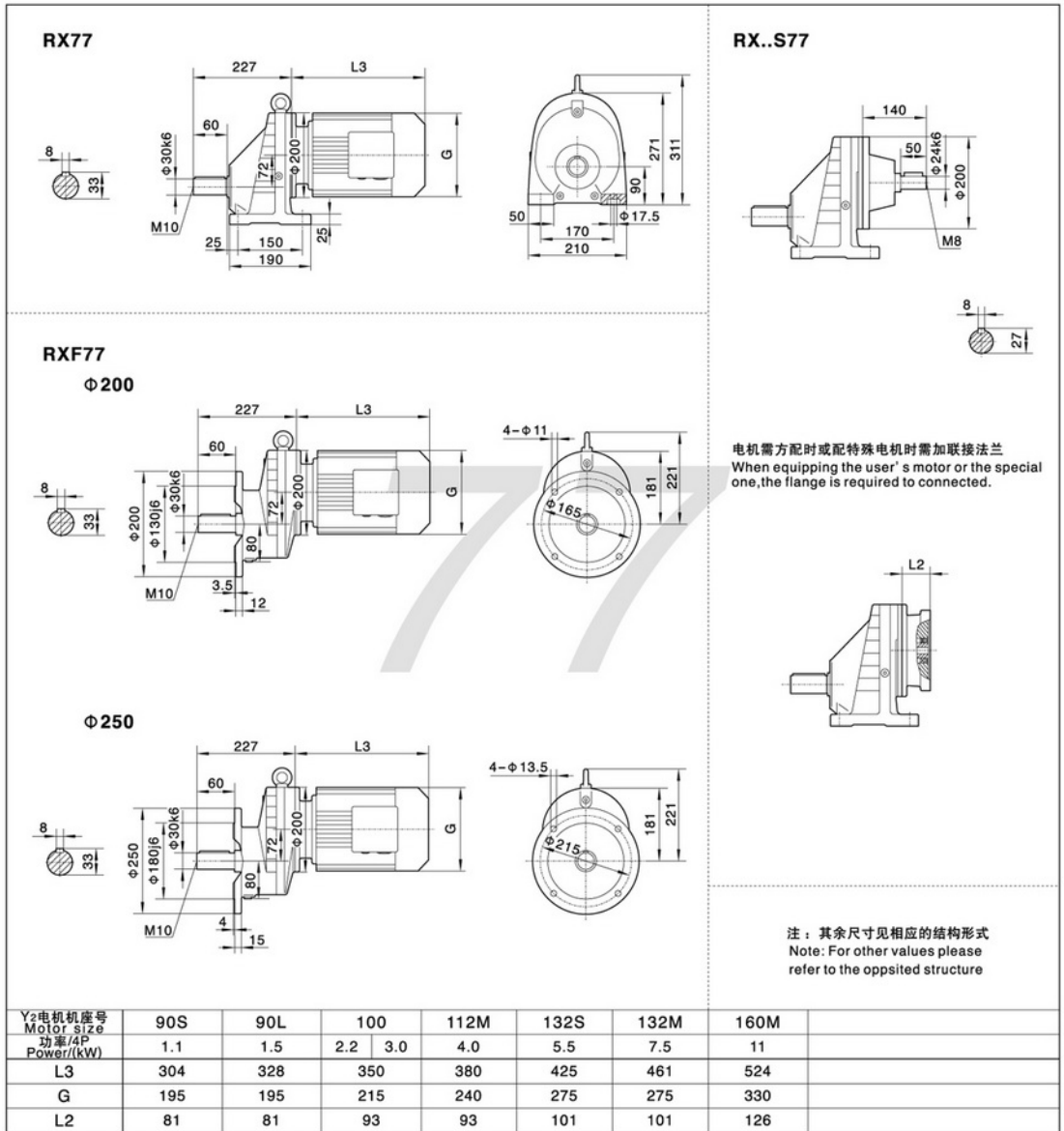

注：“RX..”表示RX、RXF
Note：“RX..”mean RX、RXF

RX87

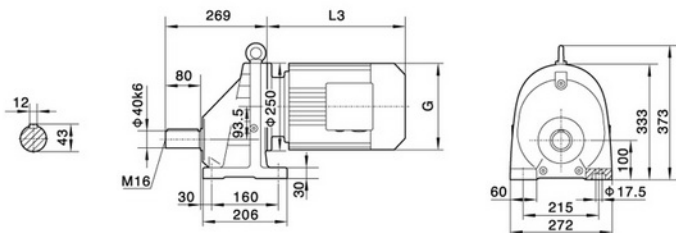

RX..S87

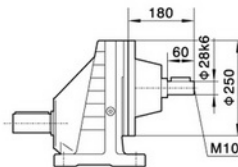

RXF87

Φ250

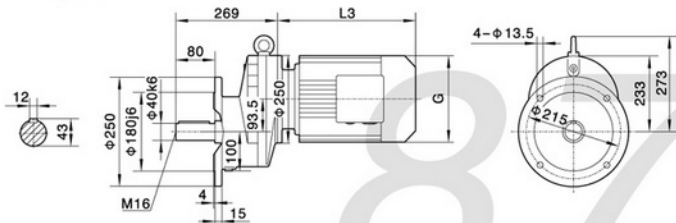

Φ300

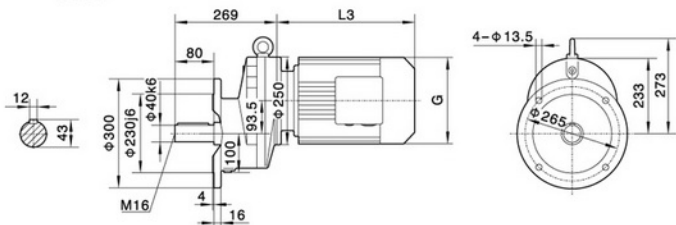

电机需方配时或配特殊电机时需加联接法兰
When equipping the user's motor or the special one, the flange is required to be connected.

R

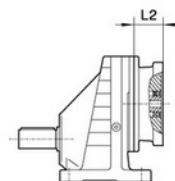

注：其余尺寸见相应的结构形式
Note: For other values please refer to the oppsited structure

Y ₂ 电机机座号 Motor size	100	112M	132S	132M	160M	160L	180M	180L	
功率/4P Power/(kW)	3.0	4.0	5.5	7.5	11	15	18.5	22	
L3	351	380	425	461	524	547	583	616	
G	215	240	275	275	330	330	380	380	
L2	71	71	101	101	126	126	126	126	

注：“RX..”表示RX、RFX
Note：“RX..”mean RX、RFX

RX107

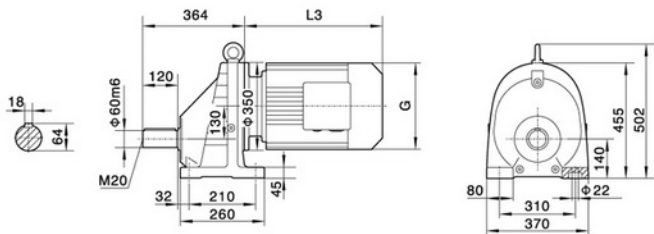

RX..S107

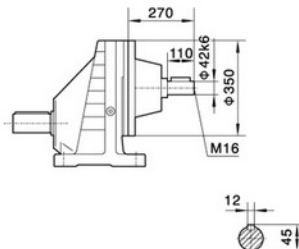

RXF107

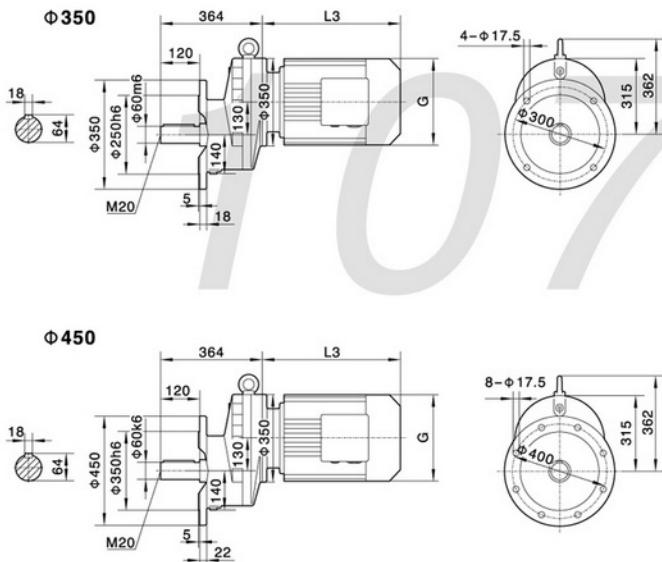

电机需方配时或配特殊电机时需加联接法兰
When equipping the user's motor or the special one, the flange is required to be connected.

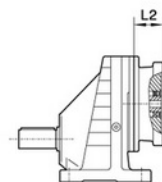

注：其余尺寸见相应的结构形式
Note: For other values please refer to the opposite structure

Y ₂ 电机机座号 Motor size	132M	160M	160L	180M	180L	200	225S	225M	
功率/HP Power(kW)	7.5	11	15	18.5	22	30	37	45	
L3	422	504	519	555	588	654	680	702	
G	275	330	330	380	380	420	470	470	
L2	101	126	126	126	126	132	132	132	

注：“RX..”表示RX、RFX
Note：“RX..”mean RX、RFX

R17

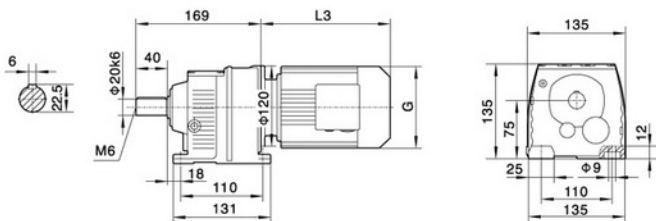

电机需方配时或配特殊电机时需加联接法兰
When equipping the user's motor or the special one, the flange is required to be connected.

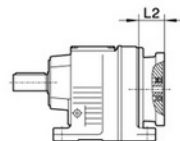

RF17

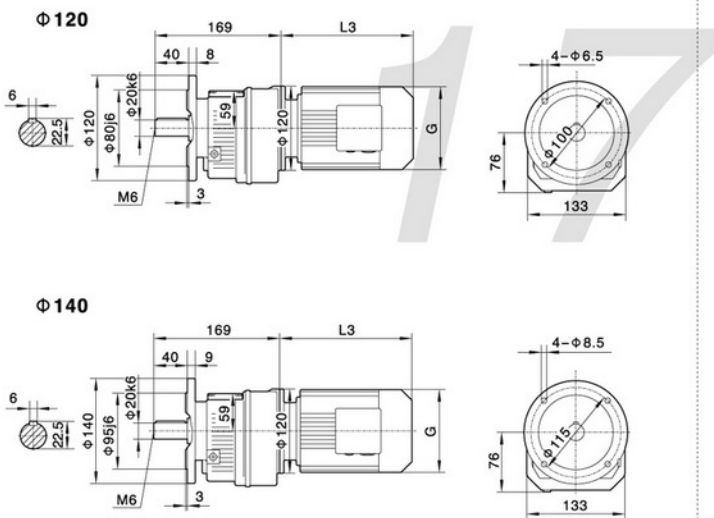

注：其余尺寸见相应的结构形式
Note: For other values please refer to the opposite structure

R

Y2电机机座号 Motor size	63	71	80							
功率/4P Power/(kW)	0.18	0.25 0.37	0.55 0.75							
L3	235	245	278							
G	130	145	175							
L2	71	71	71							

注：“R..”表示R、RF
Note:“R..”mean R、RF

R27

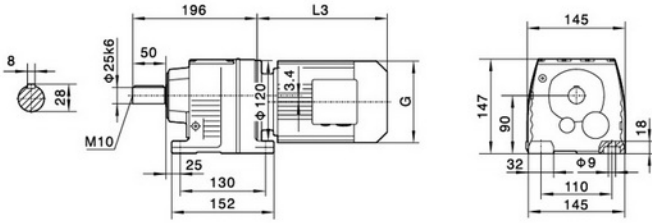

电机需方配时或配特殊电机时需加联接法兰
When equipping the user's motor or the special one, the flange is required to be connected.

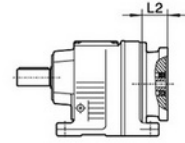

RF27

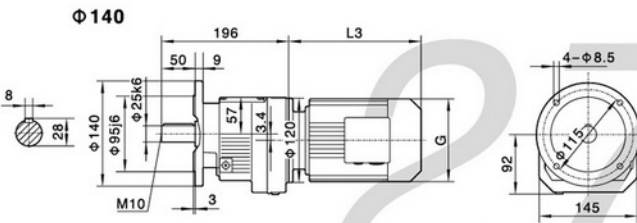

R..S27

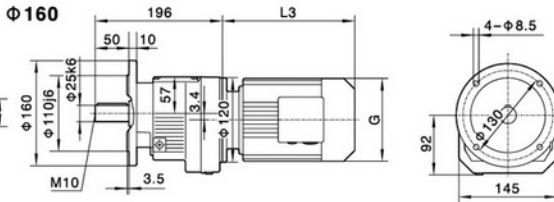
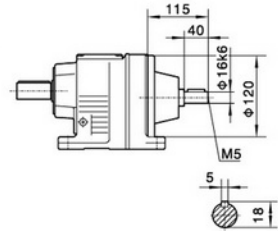

R..27R17

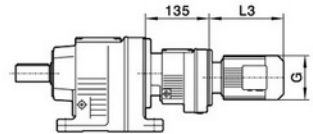

注：其余尺寸见相应的结构形式
Note: For other values please refer to the oppsited structure

Y ₂ 电机座号 Motor size	63	71	80	90S	90L	100	
功率/4P Power/(kW)	0.18	0.25 0.37	0.55 0.75	1.1	1.5	2.2 3.0	
L3	235	245	278	304	328	340	
G	130	145	175	195	195	215	
L2	71	71	71	71	71	93	

注：“R..”表示R、RF

Note：“R..”mean R、RF

R37

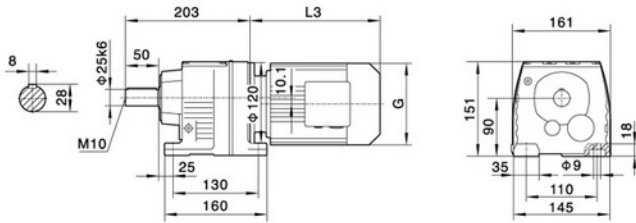

电机需方配时或配特殊电机时需加联接法兰
When equipping the user's motor or the special one, the flange is required to be connected.

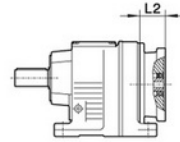

RF37

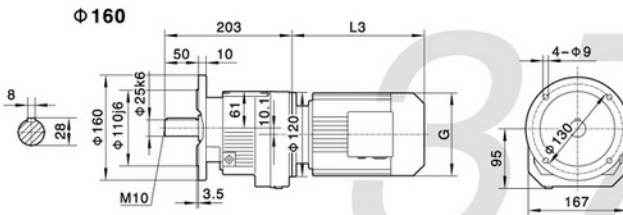

R..S37

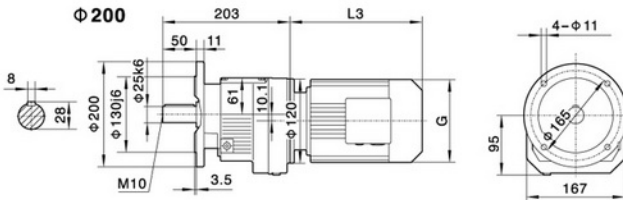
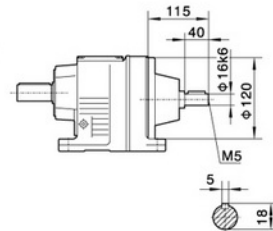

R..37R17

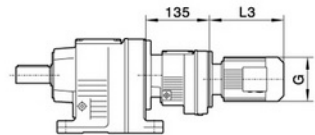

注：其余尺寸见相应的结构形式
Note: For other values please refer to the opposite structure

Y ₂ 电机机座号 Motor size	63	71	80	90S	90L	100L		
功率/4P Power/(kW)	0.18	0.25 0.37	0.55 0.75	1.1	1.5	2.2 3.0		
L3	235	245	278	304	328	340		
G	130	145	175	195	195	215		
L2	71	71	71	71	71	93		

注：“R..”表示R、RF

Note：“R..”mean R、RF

R47

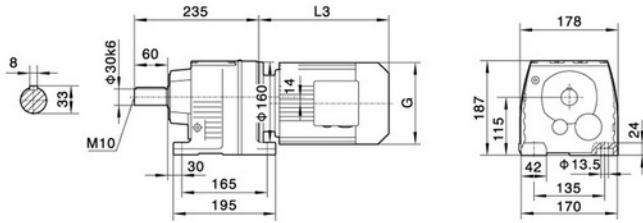

电机需方配时或配特殊电机时需加联接法兰
When equipping the user's motor or the special one, the flange is required to be connected.

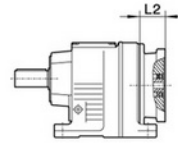

RF47

Φ 160

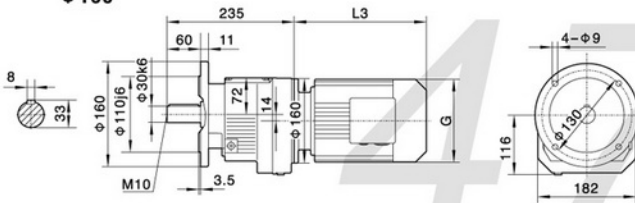

R..S47

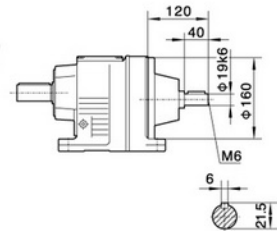

Φ 200

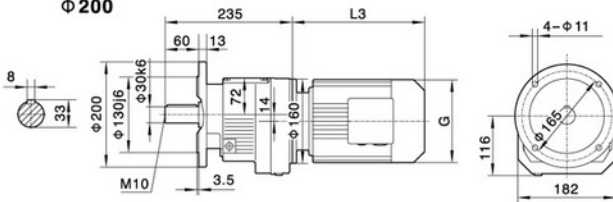

R..47R37

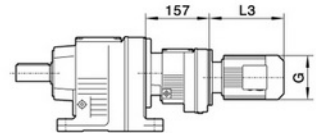

注：其余尺寸见相应的结构形式
Note: For other values please refer to the opposite structure

Y ₂ 电机机座号 Motor size	63	71	80	90S	90L	100	112M	132S	
功率/4P Power/(kW)	0.18	0.25 0.37	0.55 0.75	1.1	1.5	2.2 3.0	4.0	5.5	
L3	223	245	278	304	328	350	380	425	
G	130	145	175	195	195	215	240	275	
L2	81	81	81	81	81	93	93	101	

注：“R..”表示R、RF

Note：“R..”mean R、RF

R57

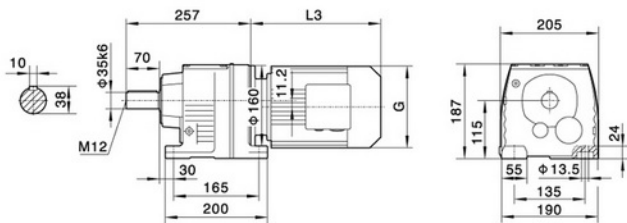

电机需方配时或配特殊电机时需加联接法兰
When equipping the user's motor or the special one, the flange is required to be connected.

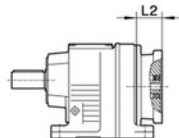

RF57

φ200

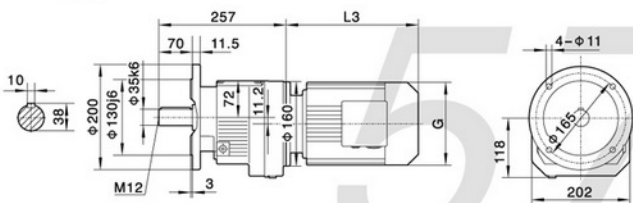

R..S57

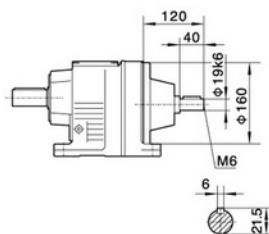

φ250

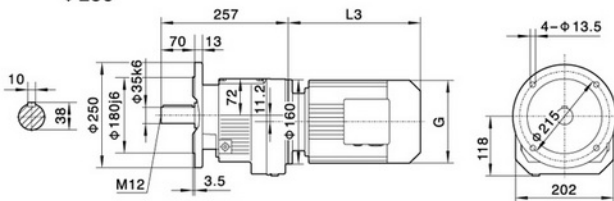

R..57R37

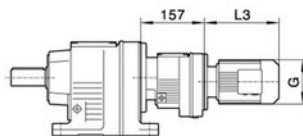

注：其余尺寸见相应的结构形式
Note: For other values please refer to the opposite structure

Y ₂ 电机机座号 Motor size	63	71	80	90S	90L	100L	112M	132S	132M	
功率/4P Power/(kW)	0.18	0.25 0.37	0.55 0.75	1.1	1.5	2.2 3.0	4.0	5.5	7.5	
L3	223	245	278	304	328	350	380	425	461	
G	130	145	175	195	195	215	240	275	275	
L2	81	81	81	81	81	93	93	101	101	

注：“R..”表示R、RF

Note：“R..”mean R、RF

R67

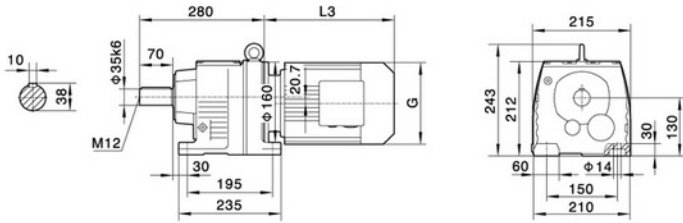

电机需方配时或配特殊电机时需加联接法兰
When equipping the user's motor or the special one, the flange is required to be connected.

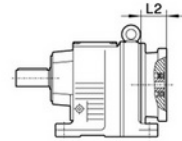

RF67

Φ200

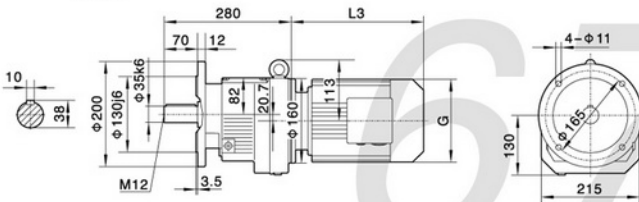

R..S67

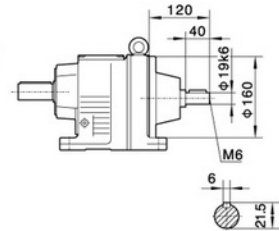

Φ250

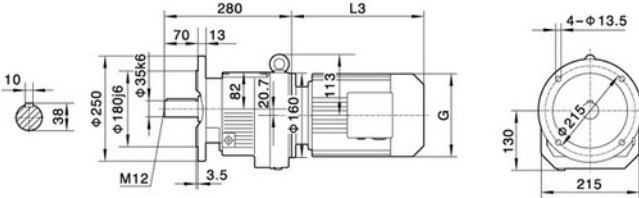

R..67R37

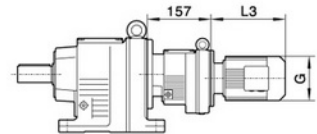

注：其余尺寸见相应的结构形式
Note: For other values please refer to the oppsited structure

Y ₂ 电机机座号 Motor size	63	71	80	90S	90L	100L	112M	132S	132M	
功率/4P Power/(kW)	0.18	0.25 0.37	0.55 0.75	1.1	1.5	2.2 3.0	4.0	5.5	7.5	
L3	223	245	278	304	328	350	380	425	461	
G	130	145	175	195	195	215	240	275	275	
L2	81	81	81	81	81	93	93	101	101	

注：“R..”表示R、RF

Note：“R..”mean R、RF

R77

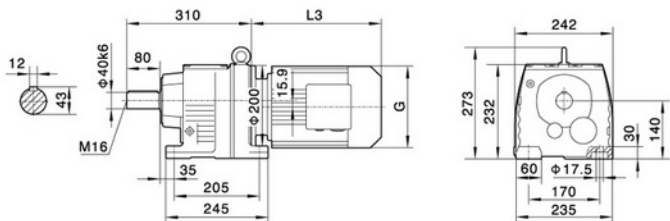

电机需方配时或配特殊电机时需加联接法兰
When equipping the user's motor or the special one, the flange is required to be connected.

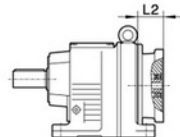

RF77

φ250

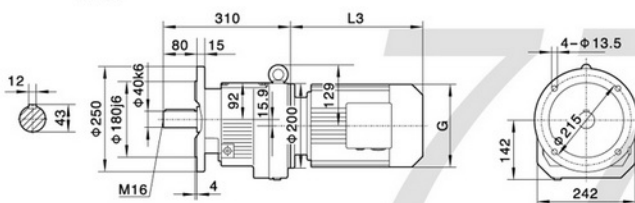

R..S77

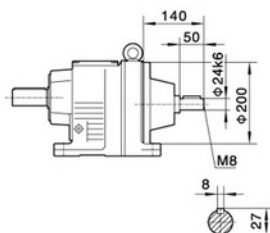

φ300

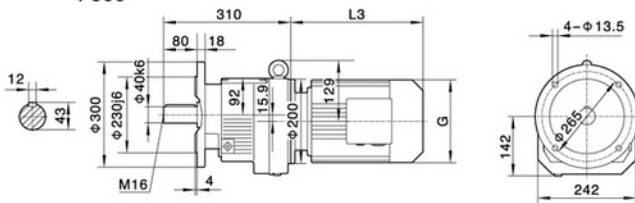

R..77R37

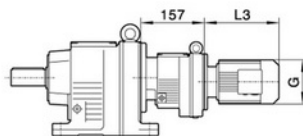

注：其余尺寸见相应的结构形式
Note: For other values please refer to the opposite structure

Y ₂ 电机机座号 Motor size	63	71	80	90S	90L	100L	112M	132S	132M	160M
功率/4P Power/(kW)	0.18	0.25 0.37	0.55 0.75	1.1	1.5	2.2 3.0	4.0	5.5	7.5	11
L3	223	233	278	304	328	350	380	425	461	524
G	130	145	175	195	195	215	240	275	275	330
L2	81	81	81	81	81	93	93	101	101	126

注：“R..”表示R、RF

Note：“R..”mean R、RF

R87

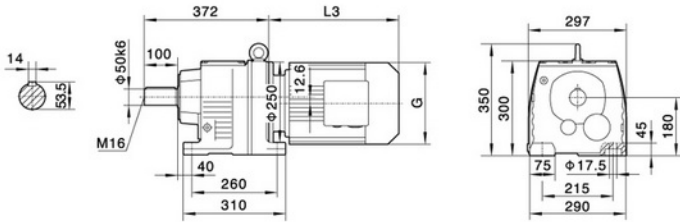

电机需方配时或配特殊电机时需加联接法兰
When equipping the user's motor or the special one, the flange is required to be connected.

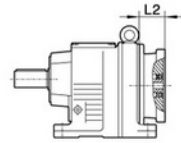

RF87

Φ 300

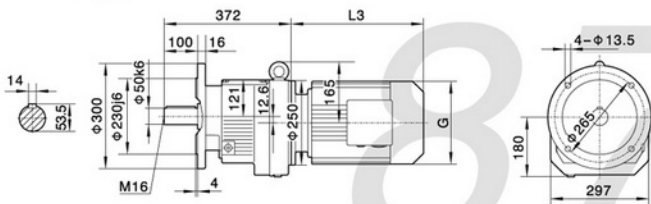

R..S87

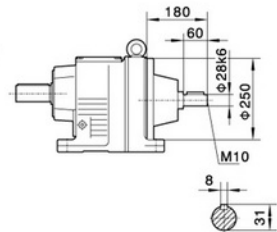

Φ 350

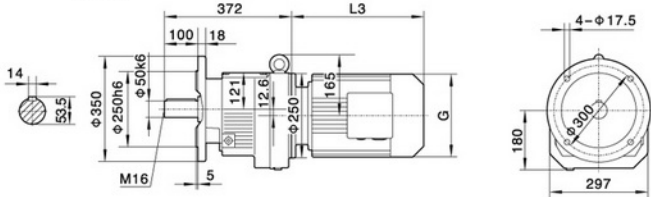

R..87R57

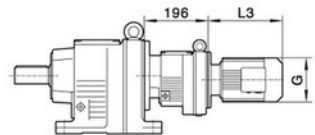

注：其余尺寸见相应的结构形式
Note: For other values please refer to the opposite structure

Y ₂ 电机机座号 Motor size	80	90S	90L	100	112M	132S	132M	160M	160L	180M	180L
功率/4P Power/(kW)	0.55	0.75	1.1	1.5	2.2	3.0	4.0	5.5	7.5	11	15
L3	246	280	304	350	380	425	461	524	547	583	616
G	175	195	195	215	240	275	275	330	330	380	380
L2	86	86	86	71	71	101	101	126	126	126	126

注：“R..”表示R、RF

Note：“R..”mean R、RF

R97

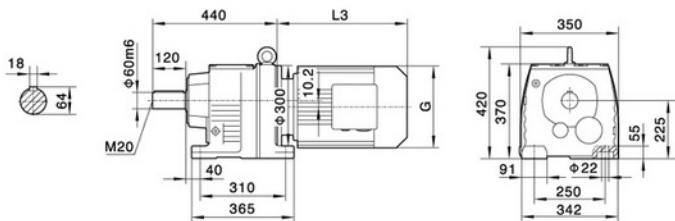

电机需方配时或配特殊电机时需加联接法兰
When equipping the user's motor or the special one, the flange is required to be connected.

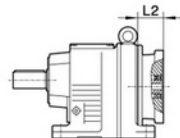

RF97

φ350

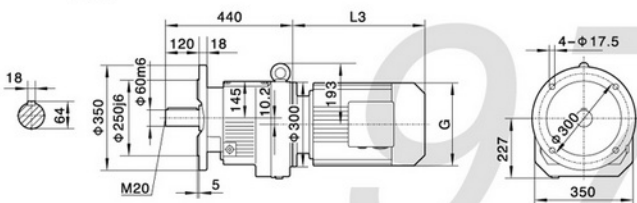

R..S97

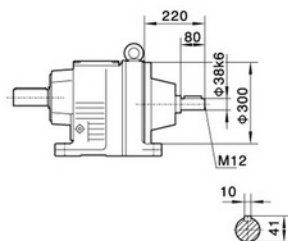

φ450

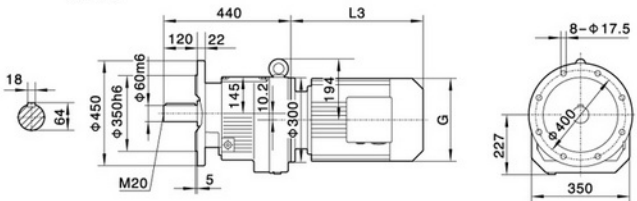

R..97R57

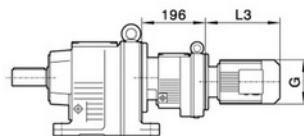

注：其余尺寸见相应的结构形式
Note: For other values please refer to the opposite structure

Y ₂ 电机机座号 Motor size	80	90S	90L	100	112M	132S	132M	160M	160L	180M	180L	200		
功率/4P Power/(kW)	0.55	0.75	1.1	1.5	2.2	3.0	4.0	5.5	7.5	11	15	18.5	22	30
L3	246	280	304	315	334	425	461	524	547	555	588	654		
G	175	195	195	215	240	275	275	330	330	380	380	420		
L2	86	86	86	101	101	101	101	126	126	126	126	132		

注：“R..”表示R、RF

Note:“R..”mean R、RF

R107

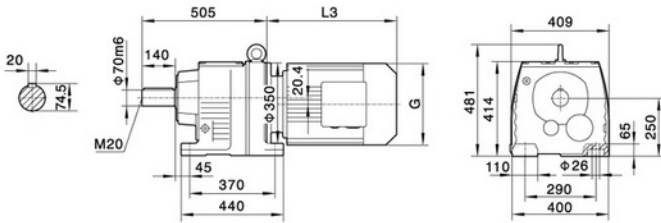

电机需方配时或配特殊电机时需加联接法兰
When equipping the user's motor or the special one, the flange is required to be connected.

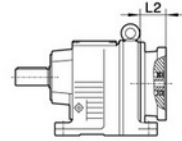

RF107

Φ 350

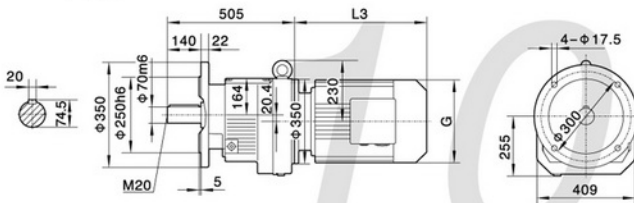

R..S107

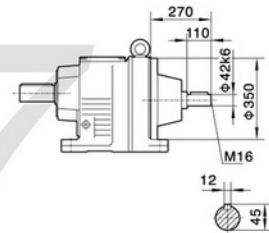

Φ 450

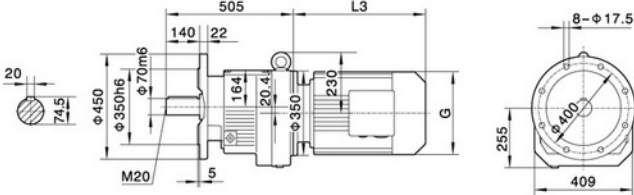

R..107R77

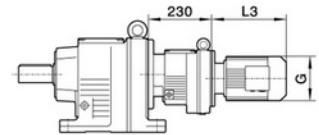

注：其余尺寸见相应的结构形式
Note: For other values please refer to the opposite structure

Y ₂ 电机机座号 Motor size	100	112M	132S	132M	160M	160L	180M	180L	200	225S	225M	
功率/4P Power/(kW)	2.2 3.0	4.0	5.5	7.5	11	15	18.5	22	30	37	45	
L3	318	334	386	422	504	519	555	588	654	680	702	
G	215	240	275	275	330	330	380	380	420	470	470	
L2	101	101	101	101	126	126	126	126	132	132	132	

注：“R..”表示R、RF

Note:“R..”mean R、RF

R137

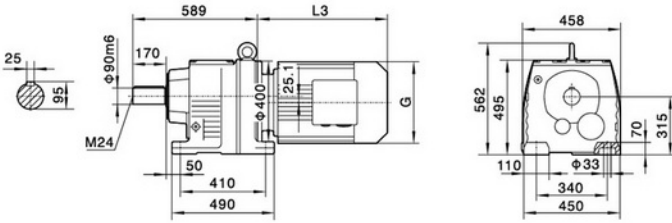

电机需方配时或配特殊电机时需加联接法兰
When equipping the user's motor or the special one, the flange is required to be connected.

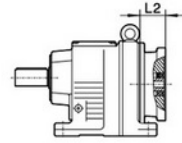

RF137

Φ450

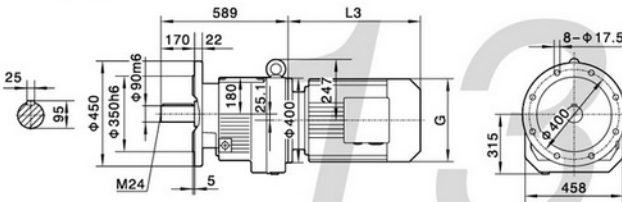

R..S137

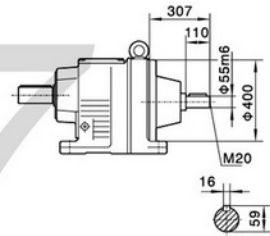

Φ550

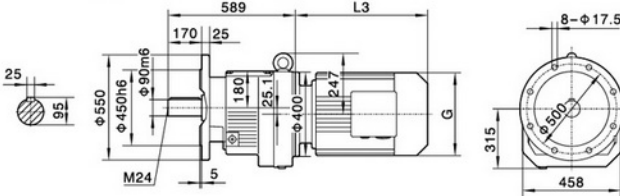

R..137R77

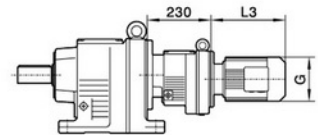

注：其余尺寸见相应的结构形式
Note: For other values please refer to the oppsited structure

Y ₂ 电机座号 Motor size	132S	132M	160M	160L	180M	180L	200	225S	225M	250
功率/4P Power/(kW)	5.5	7.5	11	15	18.5	22	30	37	45	55
L3	388	424	476	519	555	588	654	680	702	771
G	275	275	330	330	380	380	420	470	470	510
L2	126	126	132	132	132	132	132	143	143	174

注：“R..”表示R、RF

Note:“R..”mean R、RF

R147

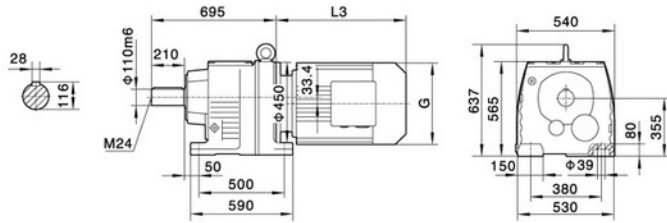

电机需方配时或配特殊电机时需加联接法兰
When equipping the user's motor or the special one, the flange is required to be connected.

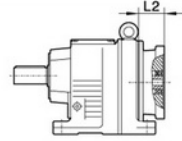

RF147

Φ450

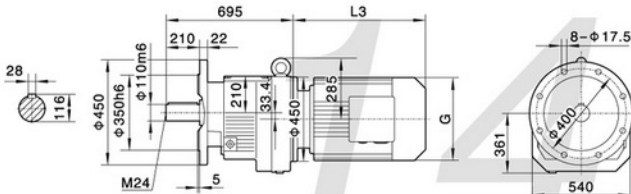

R..S147

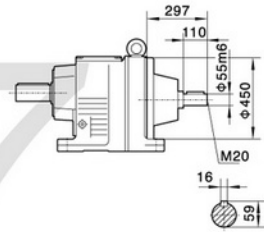

Φ550

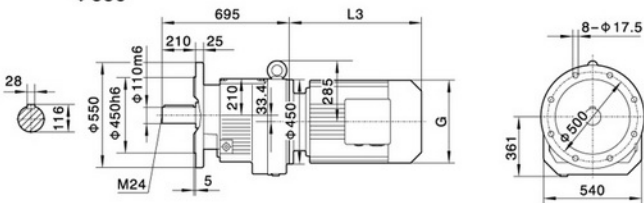

R..147R87(R77)

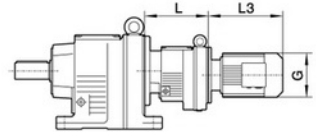

	R..147R77组合	R..147R87组合
L	226	275

注：其余尺寸见相应的结构形式
Note: For other values please refer to the oppsited structure

Y ₂ 电机机座号 Motor size	160M	160L	180M	180L	200	225S	225M	250	280S	280M
功率/4P Power/(kW)	11	15	18.5	22	30	37	45	55	75	90
L3	567	602	583	616	654	674	696	775	845	845
G	330	330	380	380	420	470	470	510	580	580
L2	132	132	132	132	132	143	143	174	174	174

注：“R..”表示R、RF Note:“R..”mean R、RF

R167

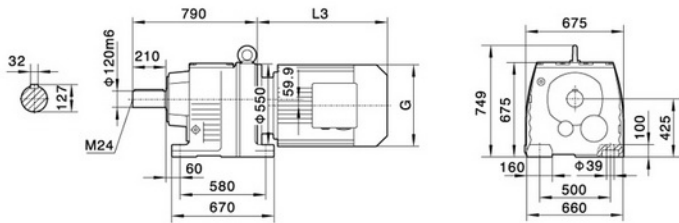

电机需方配时或配特殊电机时需加联接法兰
When equipping the user's motor or the special one, the flange is required to be connected.

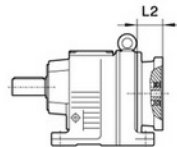

RF167

φ550

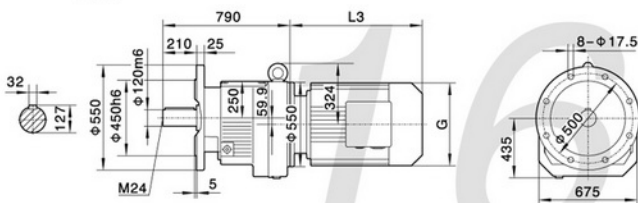

R..S167

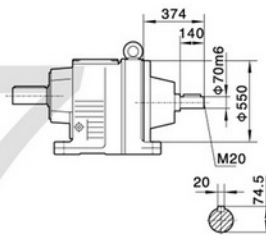

φ660

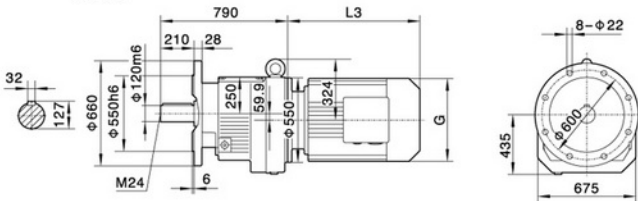

R..167R97(R107)

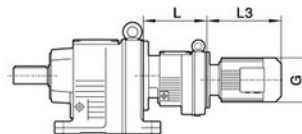

	R..167R97组合	R..167R107组合
L	320	370

注：其余尺寸见相应的结构形式
Note: For other values please refer to the oppsited structure

Y ₂ 电机机座号 Motor size 功率/4P Power/(kW)	160M	160L	180M	180L	200	225S	225M	250	280S	280M	315S	315M	315L
L3	567	602	635	666	642	669	691	770	828	879	1100	1130	1360
G	330	330	380	380	420	470	470	510	580	580	645	645	645
L2	143	143	143	143	143	143	143	113	113	113	113	145	145

注：“R..”表示R、RF

Note:“R..”mean R、RF